

Brianna Kailas

briannakailas@gmail.com

7323378610

thevoidand

New Jersey

Education

→ Bachelor of Architecture

Expected 2027

Hiller College of Architecture & Design; GPA: 3.56/4.0
New Jersey Institute of Technology; Newark, NJ

Extra Curricular Activities

→ Transect Student Publication; Newark, NJ

Fall 2024 - Current

Podcast Chair (2024 - Current): led and facilitated conversations and researched and prepared for discussion topics, questions, and relevant background information. Produced, recorded, and edited each episode.

Graphics Editor (2025 - Current): designed and laid out the publication's content. Maintained a clear and consistent visual identity that reflects the publication's academic and creative values

Student Works Curator (Fall 2024 - Spring 2025): collected, reviewed, and selected outstanding student projects for a year long exhibition at NJIT. Coordinated with professors and students to identify exemplary work across the first year studios.

→ Iteration Student Newspaper; Newark, NJ

Fall 2024 - Current

Contributor (Fall 2024 - Current): wrote for issues 005_Pendulum and 006_Ambition or Ego which included drafting, revisings, and integrating feedback to enhance clarity, tone, and accuracy. Created an affordable alternative for 006 that consisted of creating Zines to distribute at the Hiller College of Architecture and Design (HCAD).

→ American Institute of Architecture Students (AIAS); Newark, NJ

2023 - Current

Marketing and Events Director (2025 - Current): led the strategic planning, execution, and evaluation of marketing campaigns across digital and traditional channels to enhance student engagements.

Marketing and Event Coordinator (2024 - 2025): assisted with requesting for poster requests and sending purchase request forms for events.

Freedom By Design Member (2023 - Current): collaborated with interdisciplinary teams to design and implement functional solutions for Design Build. Participated in project development, site assessments, client interviews, and design proposals.

→ Future View: Vernacular Technologies, NJIT

Spring 2024

Assisted in fabricating earthen bricks in preparation for the event and provided logistical support as a runner for attendees and organizers during lectures and workshops throughout the symposium.

→ Jazz Band

Fall 2017 - Spring 2023

- Developed skills in jazz phrasing, tone control, and improvisational soloing in a variety of styles (e.g., swing, bebop, blues, Latin).
- Performed regularly as part of a school or community jazz ensemble, playing both tenor and alto saxophone.

Work Experience

→ Social Media Marketer, R.K. Industries

Summer 2021

- Created compelling content, managed posts across platforms, ran paid advertisements, analyzed metrics, and stayed up to date with trends
- Developing and executing strategic social media campaigns to enhance awareness, engage the audience, and drive business growth

Skills

Softwares: Adobe CC - Illustrator, Photoshop, InDesign, Premier Pro, Lightroom
MS Office - Word, Powerpoint, Excel
Digital Modeling - Enscape, SketchUp, ProCreate, Rhinoceros 3D

Accolades

Parette Somjen Architects Endowed Scholarship (Fall 2024)
Dean's List (2023 - 2024)
Dean's List (2024 - 2025)
DIY Gallery Recipient (2024)

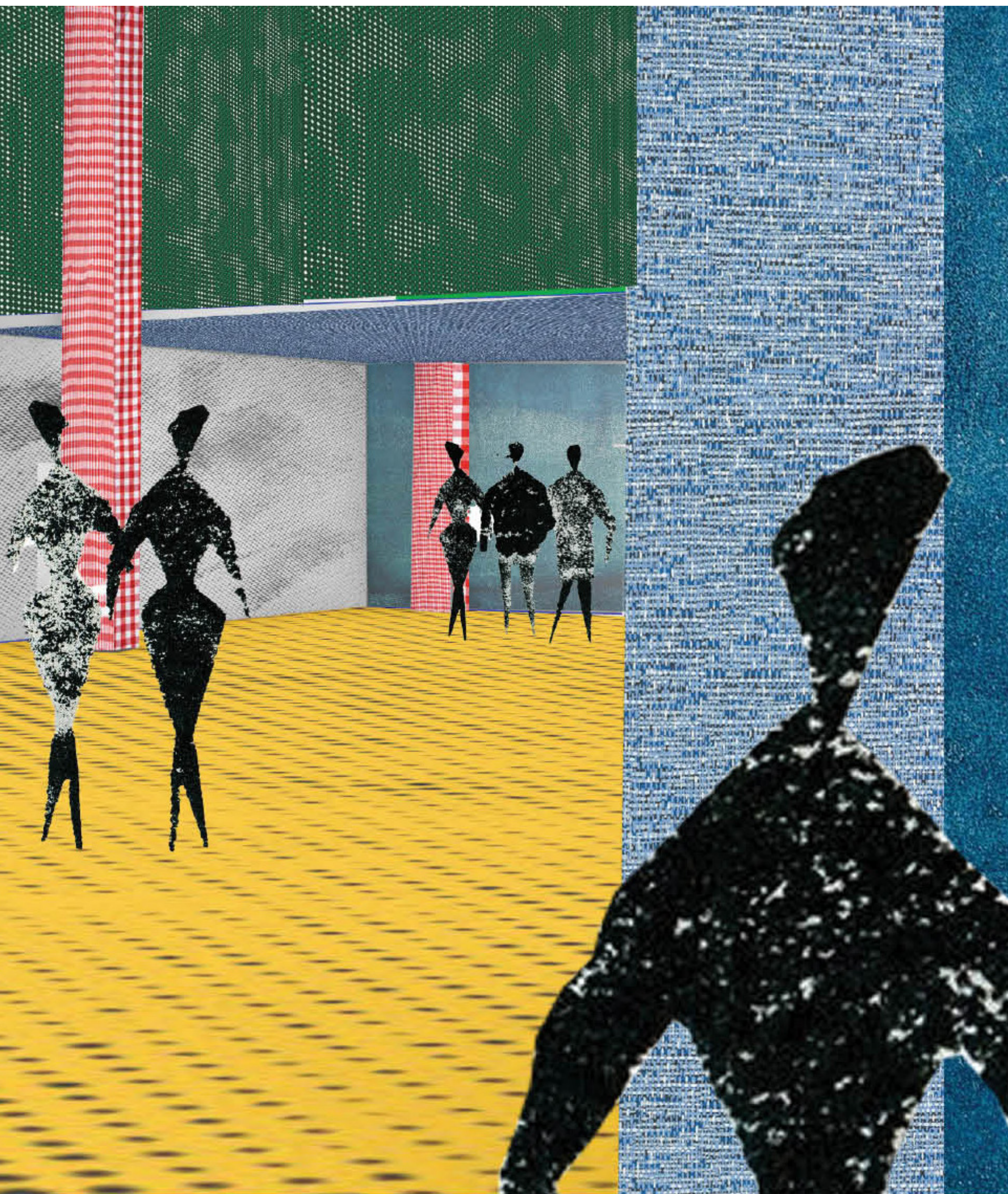

brianna kailas
selected works
2023 - 2025

exhaustion *...to create lasting works on imagination*

Branch Brook Park, NJ | ARCH295 | Fall 2024

Collaborators: Akaki Gelbakhiani & Christopher Lema

Prof. Ross A. Myren

We were asked to design an "artist in residence", live/work project in Essex County's Branch Brook Park. With our design, we aim to create a space for our client, Tom and future artists to dedicate their time to their work. Our goal is to nurture the arts by providing talented individuals with an inspiring residential environment where they can create lasting works of imagination.



section perspective NTS

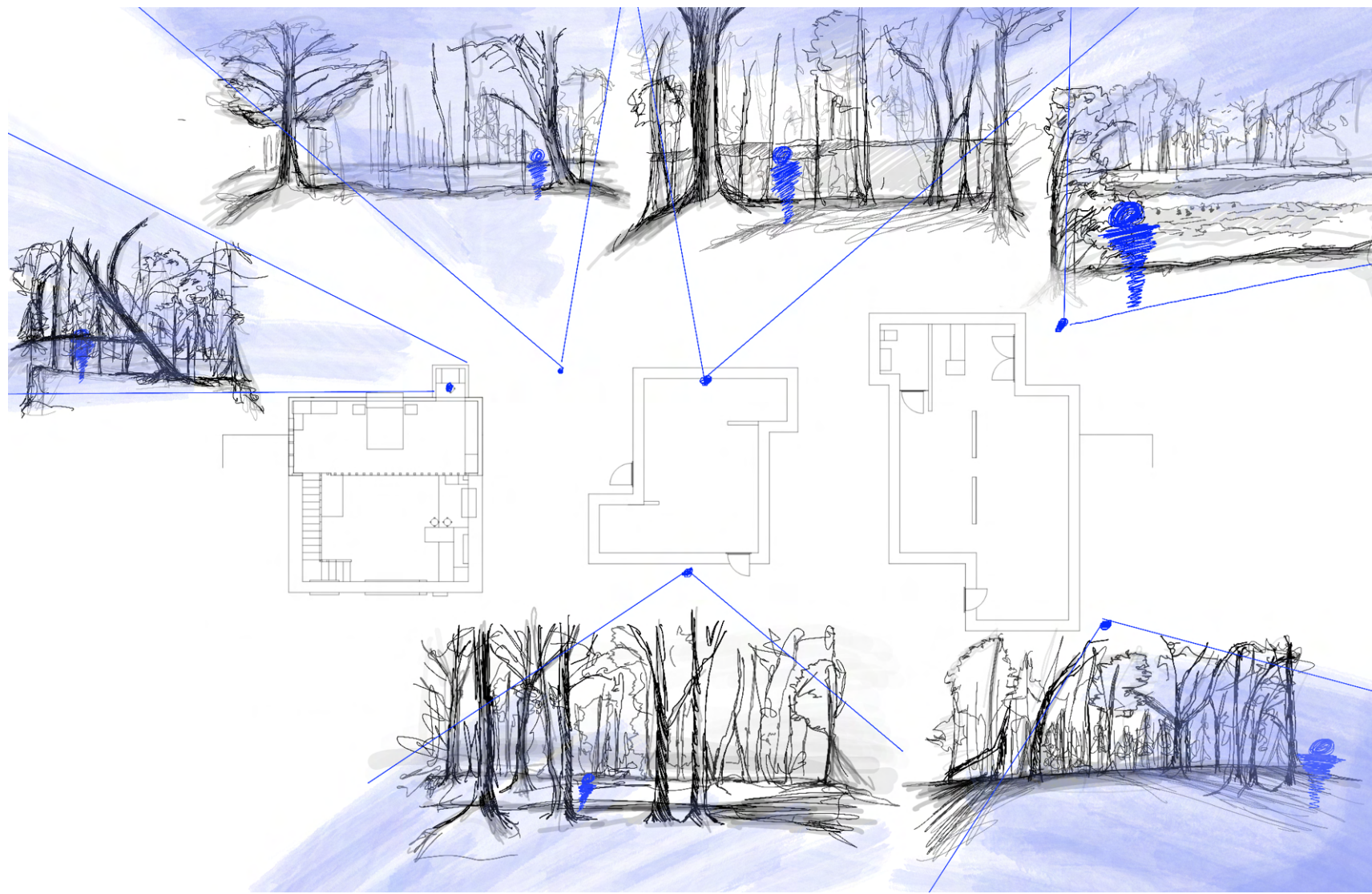

visions - concept sketches NTS

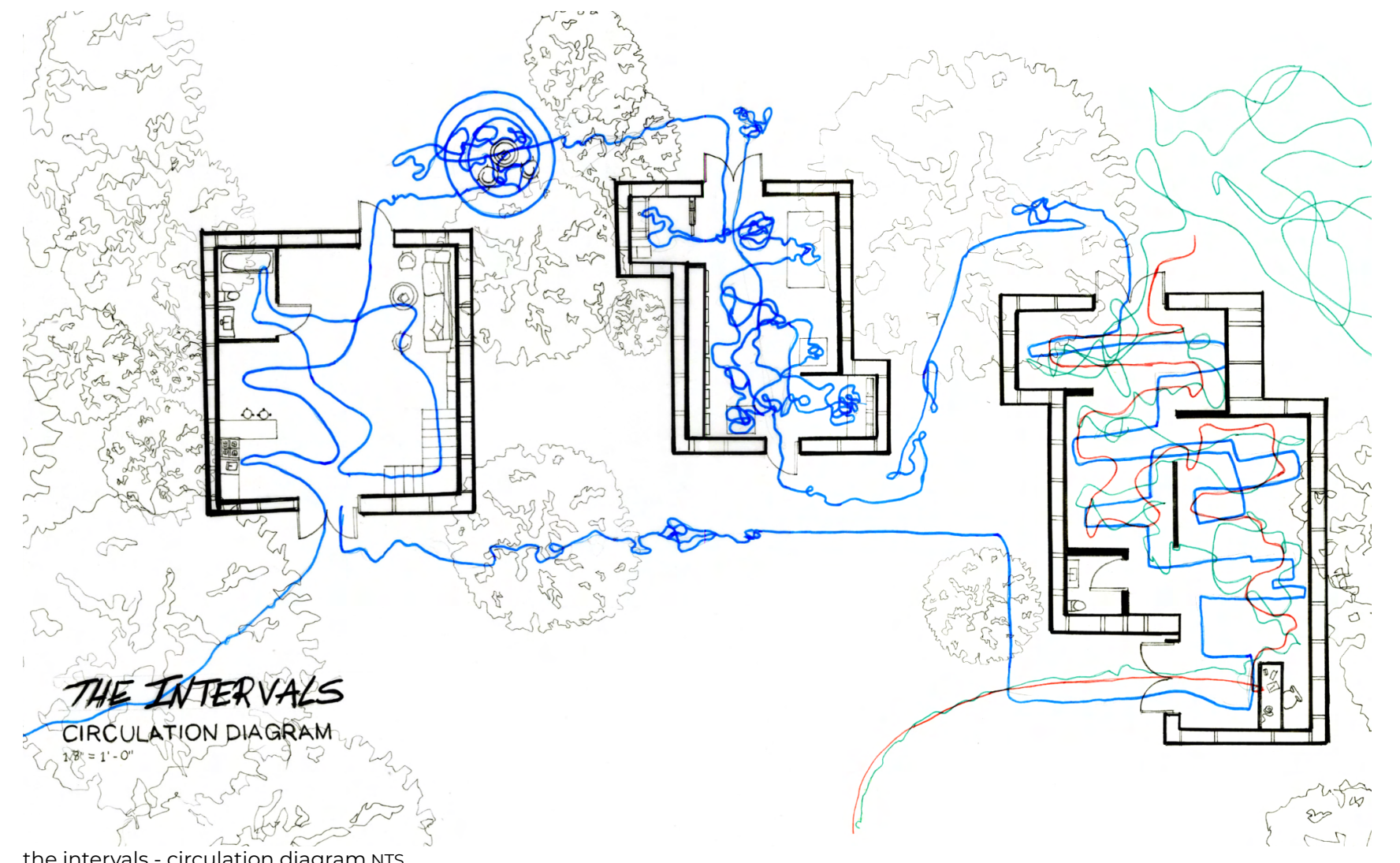

the intervals - circulation diagram NTS

paradigm ...shift happens

Newark, NJ | ARCH296 | Spring 2025

Collaborators: AHSA Studio

Prof. Saba Ardeshiri & Anthony Harrington

how do you get comfy?!??

refers to a paradigm shift that encourages the user to rethink how they approach comfortability

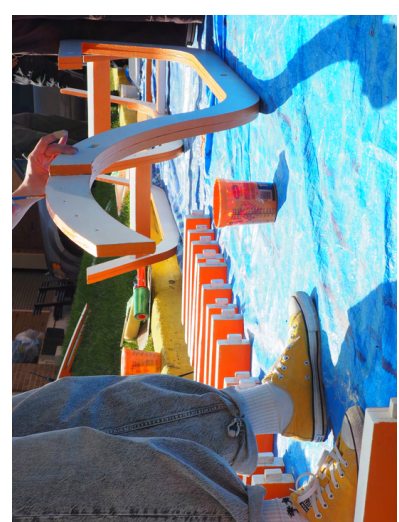
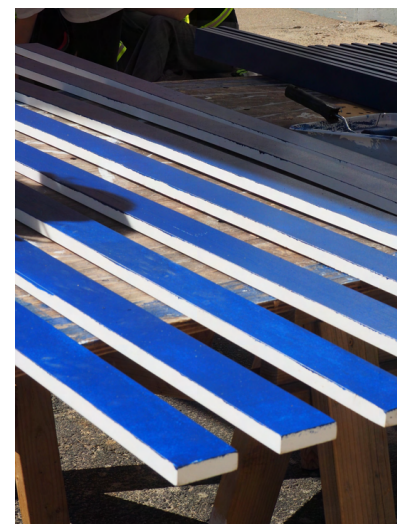

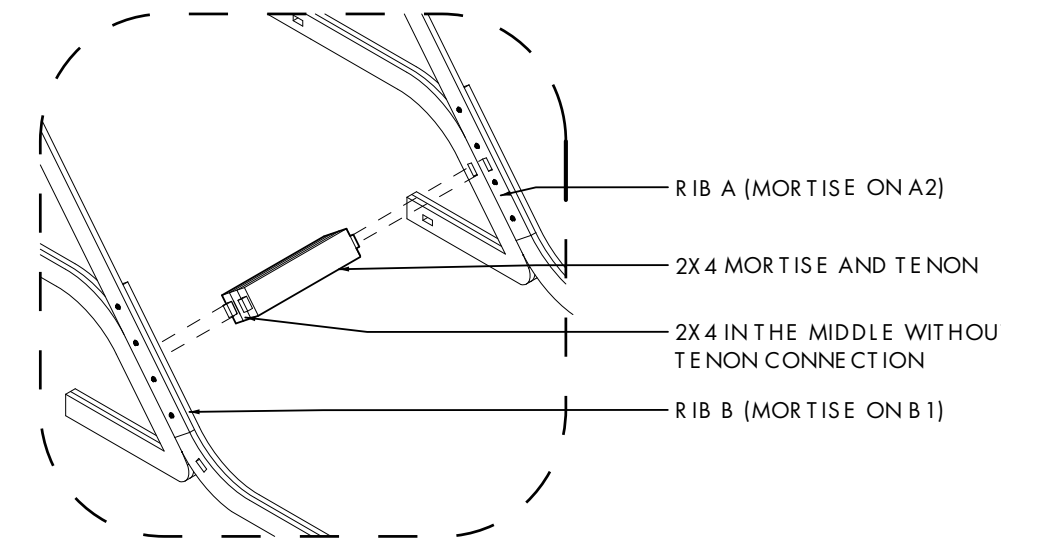
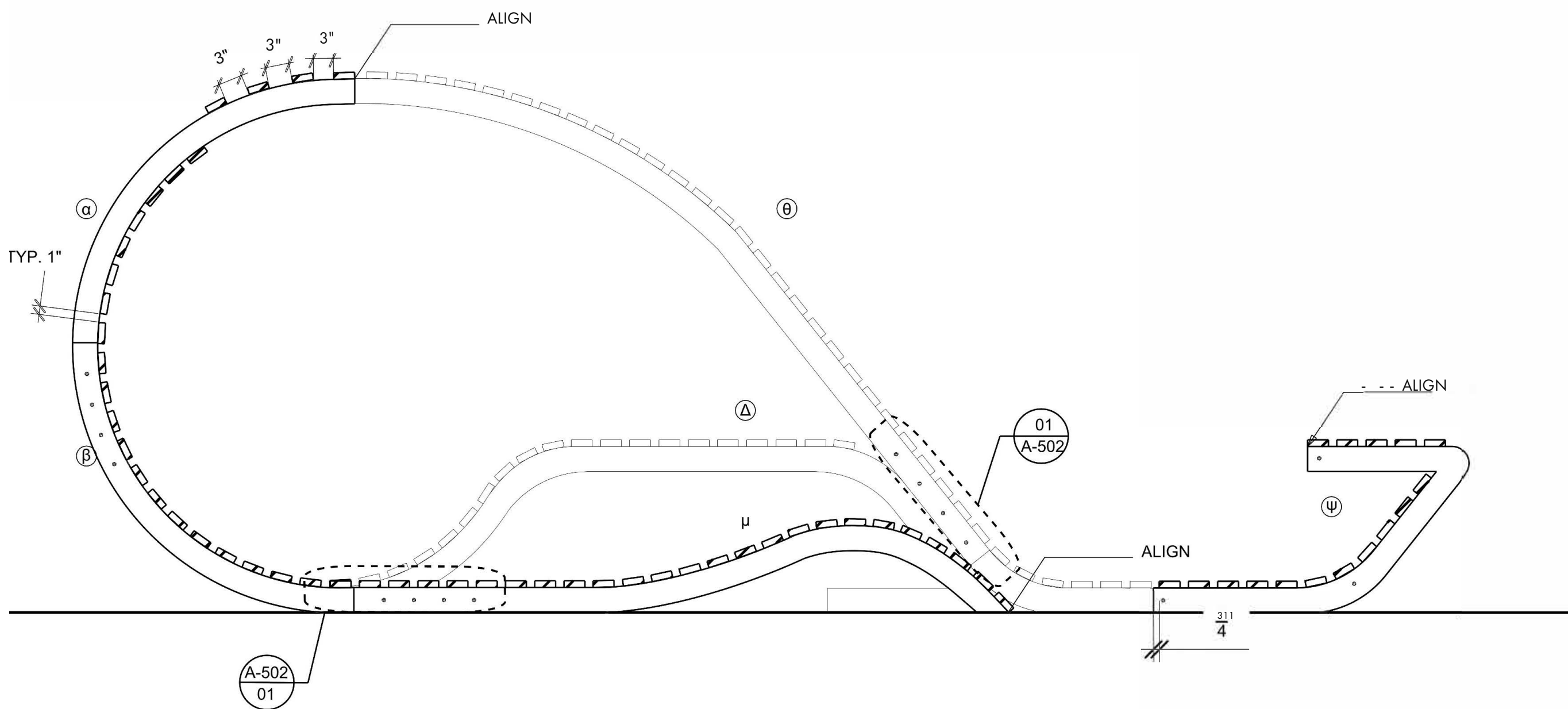
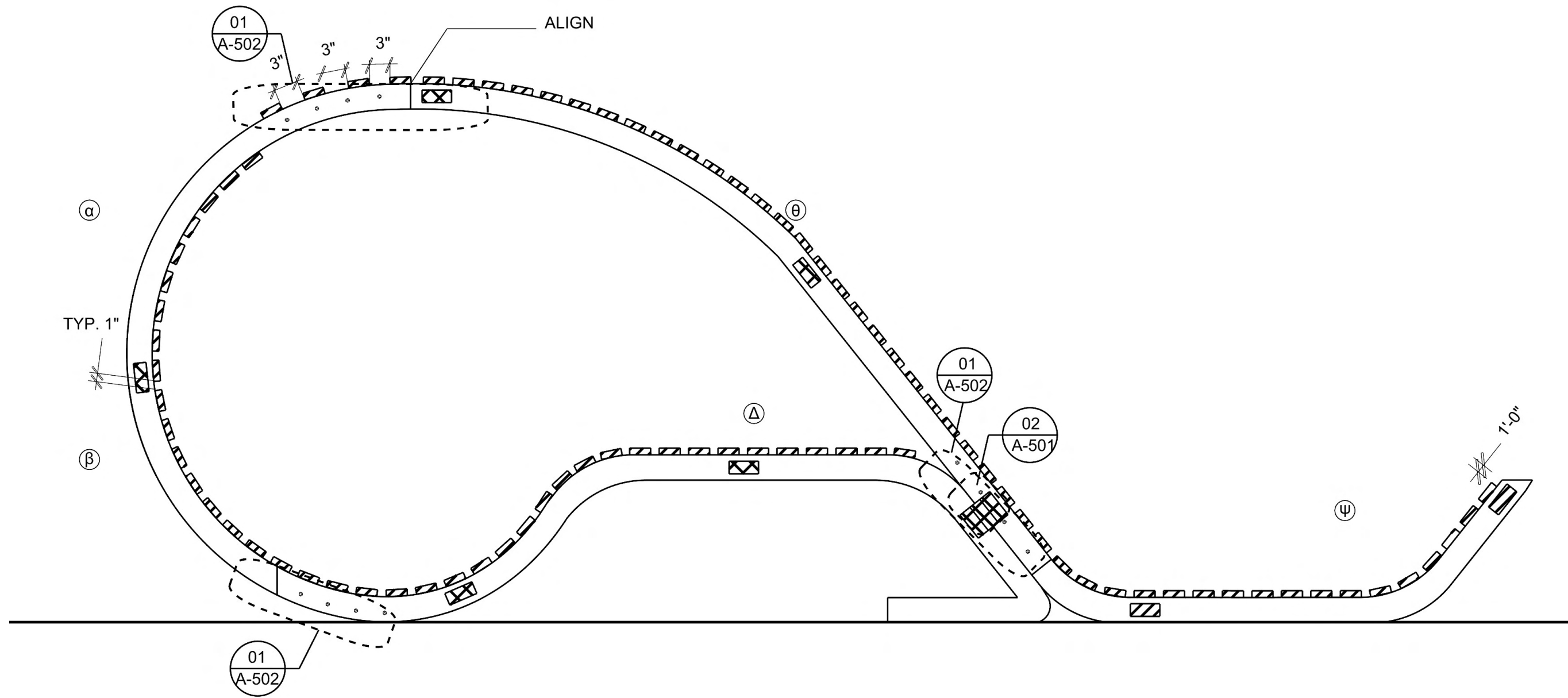

06 MODULE Ψ & Δ SPECIAL TENON
SCALE: NTS

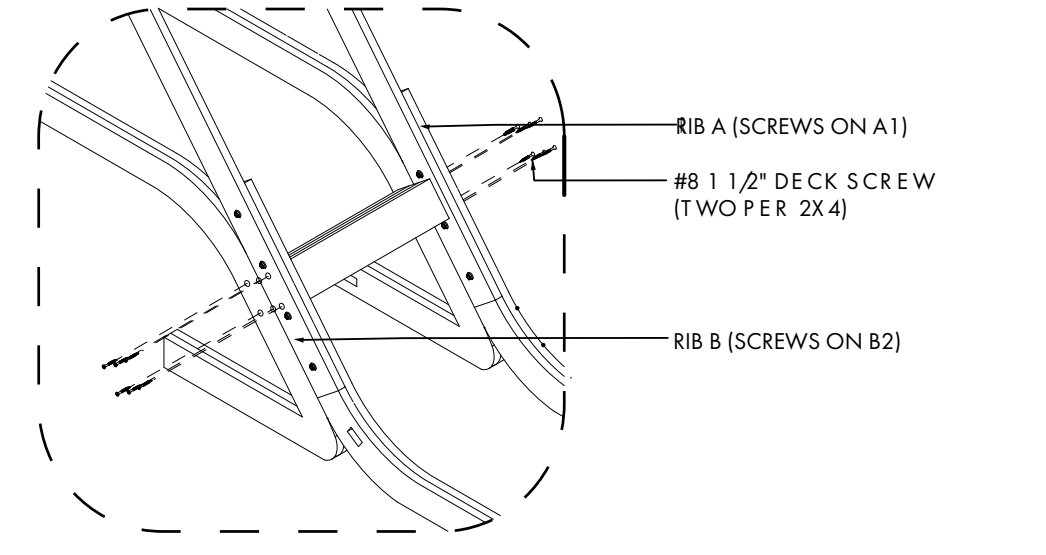

07 MODULE Ψ & Δ SPECIAL SCREW DETAIL
SCALE: NTS

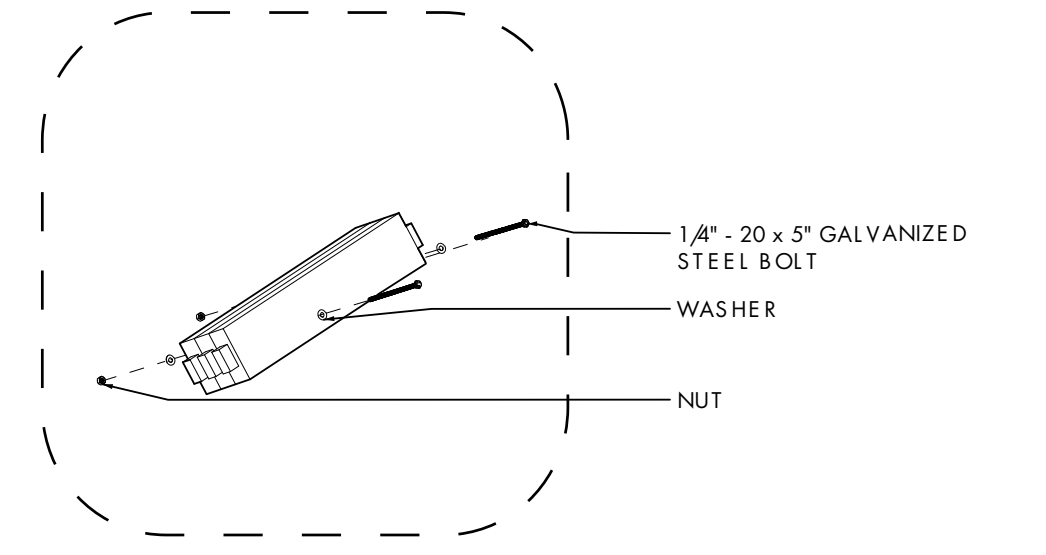

08 MODULE Ψ & Δ SPECIAL BOLT DETAIL
SCALE: NTS

lost

...to perceive beyond the obvious
door handle | ARCH 295 | Fall 2024
Prof. Ross A. Myren

[inconspicuous] the entrance is only discernible to those with the insight to perceive beyond the obvious. To gain access, individuals must possess an intuitive understanding of the intricacies of the door mechanism and its handle, demonstrating a keen awareness of the hidden components that facilitate entry. Those who lack this understanding will find themselves excluded from entering.

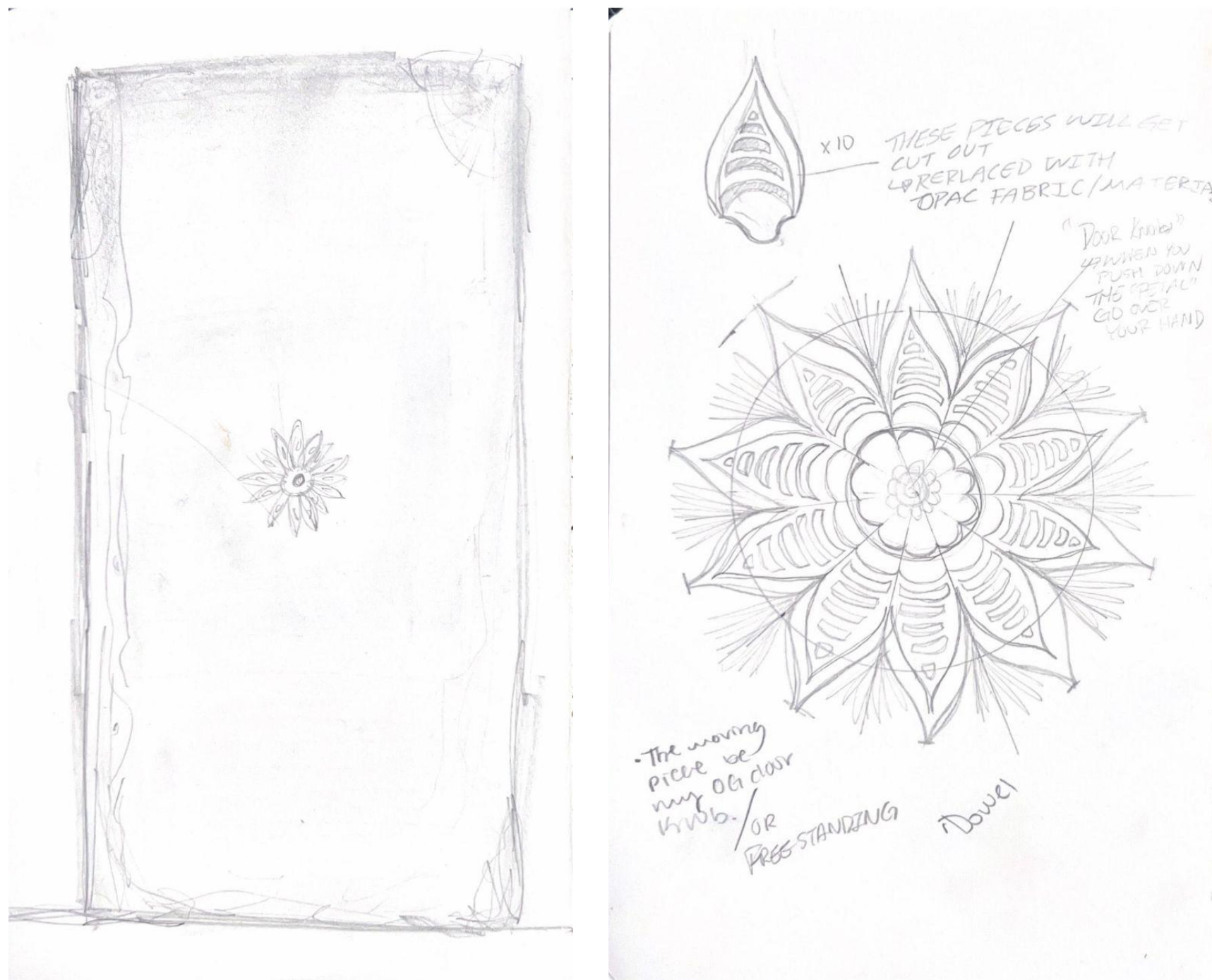
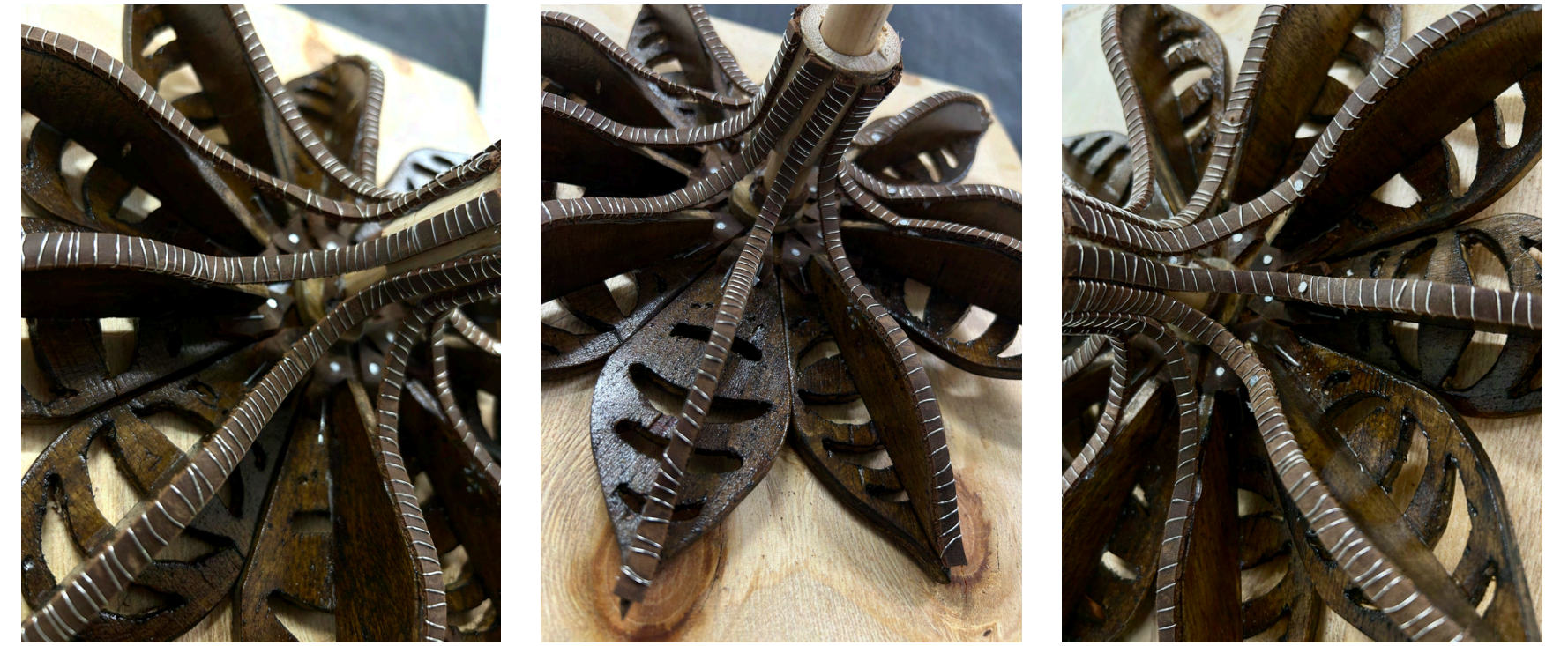

fabrication sketches



lit[t]erature *...the ecology & the integrity*

Laurel Hall, Newark, NJ | ARCH295 | Fall 2024

Collaborators: Nick Diaz

Prof. Ross A. Myren

Beach pollution has emerged as a pressing global issue, affecting not only the natural beauty of coastlines but also the health of marine ecosystems and the well-being of communities that rely on these environments. From plastic debris and chemical runoff to sewage discharge, various forms of pollution threaten the delicate balance of marine life and pose significant risks to beachgoers. As tourism and recreational activities flourish in coastal areas, the consequences of pollution become evident, promoting urgent calls for sustainable practices and community engagement. Addressing this issue is essential for preserving our beaches for future generations and maintaining ecological integrity of our beaches and oceans.



trash catalog

carnovsky - ocean pollution reality



dead fish



pollution



alive fish



Periodic Table of Sea Bright Beach Litter

| | | | | | | | | | | | | | | | | |
|--|---|---|--|---|--|--|--|---|--|---|---|---|--|---|---|--|
| Pb Plastic Bag  | | | | | | | | | | | | | | Fc Fabric  | | |
| B Ballon  | Fb Fish Bait  | | | | | | | | | | | Fs Starfish  | Wf Witch Finger  | W Water Bottle  | G Gallon  | Li Lids  |
| So Solo Cup  | R Raichu  | Va Vape  | Bc Bottle Caps  | Ic Iced Coffee Cups  | Rg Ring Pop  | F Floss  | Nb Nerf Bullet  | Ka Kool-Aid Burst  | Bh Bucket Handle  | Z ZYN  | Dc Drain Catcher  | Pt Party Tins  | Am Army Man  | | | |
| Sy Scrunchie  | Fw Food Wrappers  | Rs Receipts  | Pp Plastic Pieces  | Sb Sports Balls  | W Wet Wipes  | Sc Shotgun Cartridges  | Nw Newspaper  | Ws Wrappers  | Ls Lifesaver  | Tt Utensils  | S Surf Leesh  | Pk Packaging  | By Binkey  | | | |
| Kx Kleenex  | Pc Plastic Cup  | Tb Tube Socks  | U Utensils  | V Velcro  | Be Beer Cap  | Pr Paper  | Fm Foam  | Pa Paper Plates  | Mc Math Cube  | Bs Ballon String  | Cc Croc & Shoe  | Gi Glowstick  | Hp Hard Plastic  | | | |
| XX Tissue Paper  | L Lighter  | At Alligator Water Toy  | Db Deflated Ballons  | V Vampire Teeth  | Tp Tupperwear  | Oi Foil  | Ee Ear Plugs  | Pf Plant Food  | Sw Straws  | Wh Wheel  | Bp Ballpoint Pen  | Bh Brush  | | | | |
| | | | Cc Caps  | Dt Deodorant  | Fm Foam  | Gf Green Foam  | Oy Sand Toy  | Hh Hairtie  | Lp Lipsticks  | | | | | | | |

pegasus *...look up*

Appalachian Trail, NJ | ARCH 195 | Fall 2024

Prof. Thomas Ogorzalek

to encompass nature on an intimate level while being protected from the elements of the environment and to observe the constellation (pegasus) at night. the pegasus is a shelter that is designed to enhance the experience of nature through different senses.

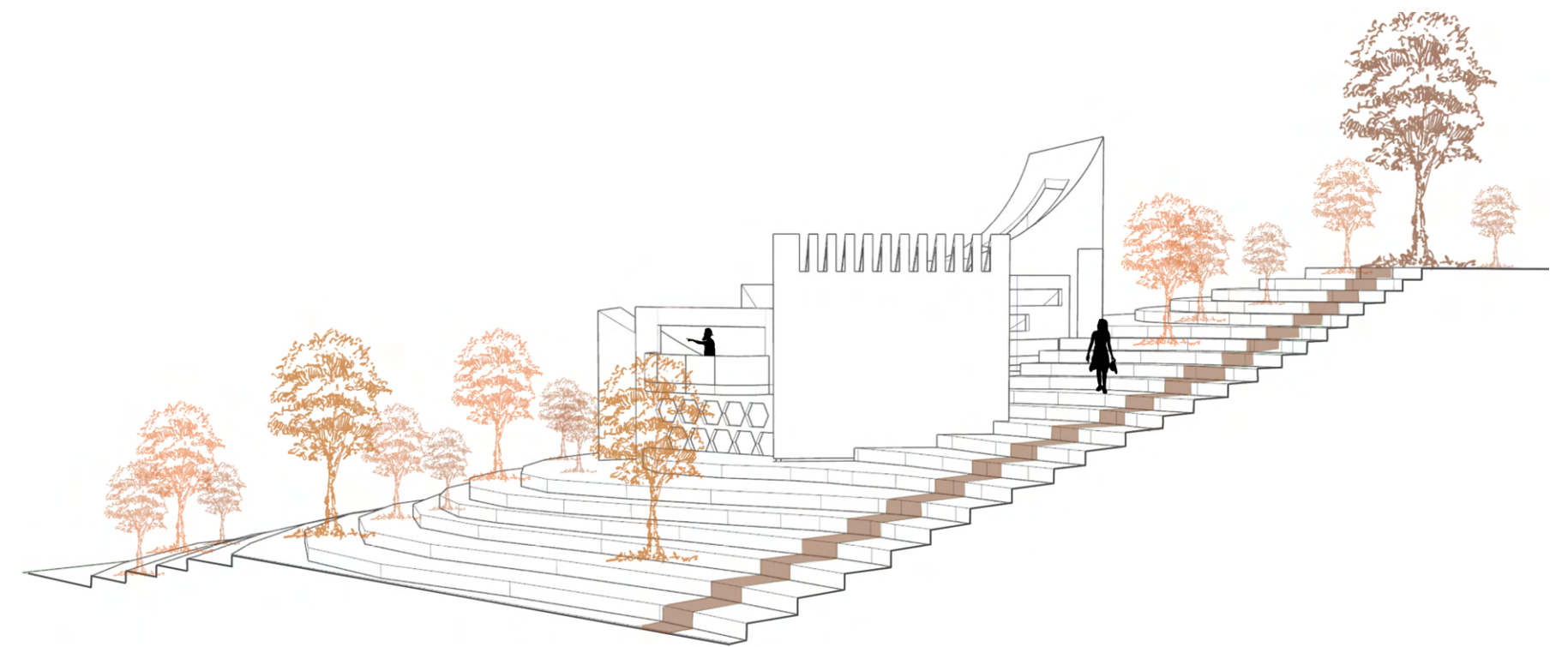
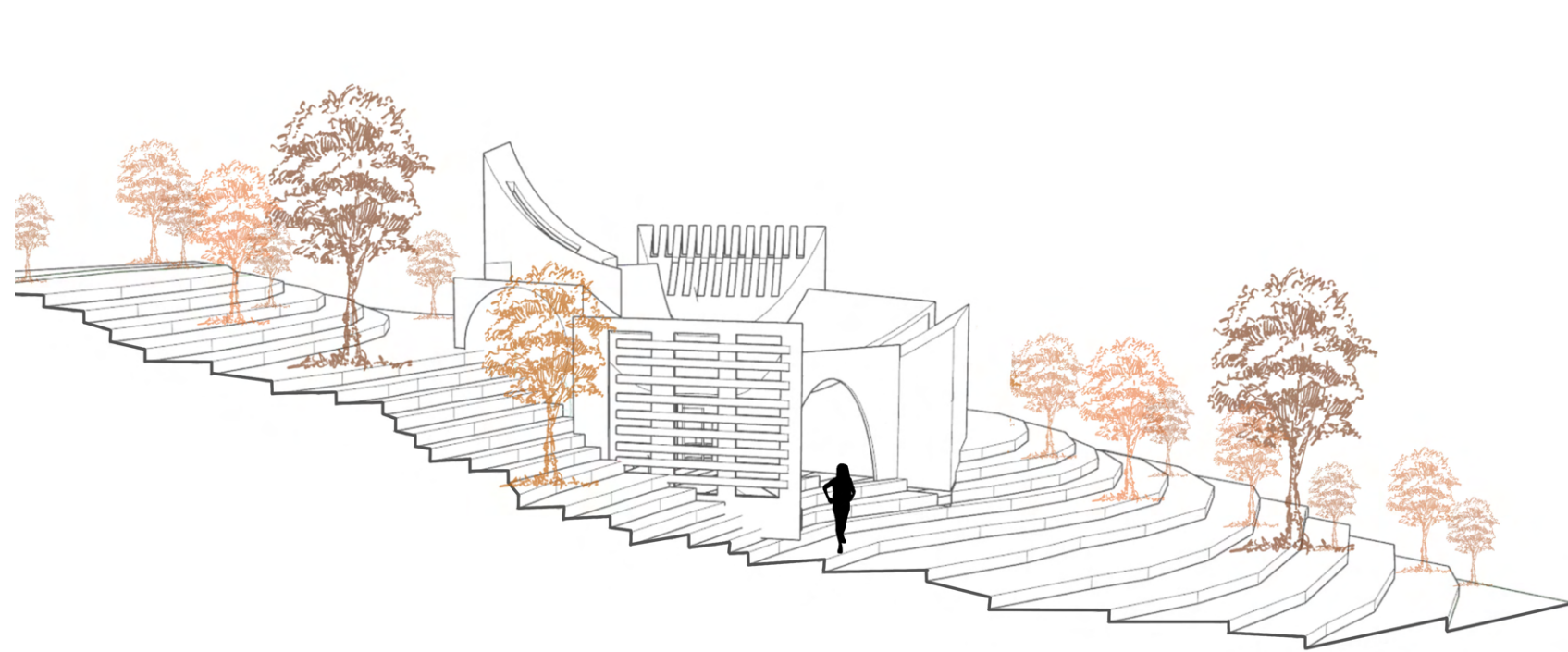

site axonometric *NTS*



to be continued...
2023 - xxxx