

SUMMARY

Dedicated and results-driven Architect currently advancing my expertise through a Master of Science in Architecture at the New Jersey Institute of Technology. Boasting a strong foundation built on over two and a half years of hands-on experience in crafting outstanding designs for diverse projects across hospitals, hospitality, and residential spaces in India. My proven proficiency in project management and architectural design reflects a commitment to delivering excellence across all facets of my work. I am eager to contribute innovative solutions and strategic thinking to a dynamic team, poised to bring unparalleled creativity and expertise to elevate your organization's projects and goals.

EDUCATION

Hillier College of Architecture and Design - NJIT	Present
Masters of Science in Architecture	Newark, NJ
<ul style="list-style-type: none">CGPA: 3.4/4.0Relevant Courses:<ul style="list-style-type: none">Urban Design Studio Geographical Information Systems(GIS) Net Zero Building Design Tools & Techniques	

TECHNICAL & KEY SKILLS

Technical Skills: **Autocad • Rhino • Revit • Photoshop • Illustrator • Indesign • Lumion • Enscape • Microsoft Office Suite •**
Key Architectural Skills: **Architectural Design • Design Presentations • Requirement Analysis & Gathering • Client Relationship Management • Cross-functional Team Support • Construction Drawings**

WORK EXPERIENCE

Architect	Aug 2022 - May 2023
Shahen Mistry Architects	Mumbai, India

Design Project and work Role

- Three residential projects:** Residential Interior: Headed client meetings, planning, designing, executing, and coordinating projects in heritage buildings, focusing on structural repairs and damages, completed in 4-6 months.
- Luxury Villa:** Interior and Architecture: Collaborated with two architects to prepare high-value conceptual design for themed villa, including landscape, construction, supervision, and material selection for an environmentally friendly project.
- Villa:** Led technical construction drawings and following up with civil and development team on site.
- Office Project:** Headed initial client meetings to the final planning, design, and coordination with all relevant stakeholders.

Architectural Research Intern	Feb 2022 - Aug 2022
Urban Design Lab- Published the following papers.	Mumbai, India

- Article 1: **Makeshift Urbanism:** Makeshift Urbanism embraces impermanence as a means to explore new alternatives, improve livability, alleviate political austerity, and ultimately enhance spatial dynamics.
- Article 2: **New Urbanism Perspective on Urban Planning of Singapore:** The New Urbanism movement advocates for human-scale, community-focused neighborhoods that enhance accessibility, and community connections, ultimately improving the quality of life.
- Article 3: **Recalibrating Living Dimensions of Heritage Sites:** The local community surrounding a heritage site plays a crucial role in its evolution, forming invisible circles surrounding the site, despite the ambiguity of defining "local community."
- Article 4: **Dharavi – A city within a city:** Dharavi, Asia's largest slum development, is a major eyesore in Mumbai's urban landscape, characterized by poor living conditions, open sewage, and packed huts.

Junior Architect	Aug 2021 - Jan 2022
Snow World Entertainment	Mumbai, India

Design Project and work Role

Collaborated with a team of two architects and a principal designer to drive the following projects from conceptualization to completion. Led efforts in concept development, final design, construction drawings, material market study, bills of quantities, and on-site coordination for seamless execution.

- Game Palacio:** A Luxurious themed resto-bar and nightclub with bowling and gaming arcade, Hospitality Interior
- Pink Wasabi:** A pink themed Japanese Restaurant, Hospitality Interior
- Game Ranch:** A Ranch themed resto-bar and nightclub with bowling and gaming arcade, Hospitality Interior
- Game Garden:** A Forest themed resto-bar and nightclub with bowling and gaming arcade, Hospitality Interior

Junior Architect

Jan 2021 - Aug 2021

Clancy Global

Mumbai, India

Design Project and Work Role

- **Nine Cloudnine Maternity Hospitals in pan India- 3.3 lakh Sq.ft overall area of all projects combined:**
- Led a collaborative effort with a team of three architects to successfully deliver nine hospital projects within stringent deadlines.
- Prepared strategic planning and conceptualization, development of floor layouts, interior styling, material selections, market visits, client management, preparation of bills of quantities, creation of construction drawings and GFCs, on-site visits, team coordination, inspection, and overseeing final handovers.

Architectural Internship

Aug 2018 - May 2019

Ingrain Architects

Mumbai, India

Design Project and Work Role

- **Ulhasnagar Market House:** Conceptual Stage development with initial design strategies.
- **Gol Maidan (Garden):** Conceptual Stage development with initial design strategies.
- **Club Complex:** Conceptual Stage development with initial design strategies.
- **Mumbai-IKEA, Magathane, India:** First conceptual design prepared for the development of IKEA factory outlet in Mumbai

PROJECT- FREELANCE

- **3 BHK Apartment:** Residential Interior Design, 1300 sq. ft approx. The total carpet area is designed
- **Dental Clinic:** Commercial Interior Design, 675 sq. ft approx. The total carpet area is designed
- **2.5 BHK Apartment:** Residential Interior Design, 900 sq. ft approx. The total carpet area is designed
- **Living Room:** Residential Interior Design, 250 sq. ft approx. The total carpet area is designed

LEADERSHIP EXPERIENCE

- Execution head for College Magazine | CTES College of Architecture, Mumbai University |

EXTRACURRICULAR ACTIVITY

- Presented Thesis Research a **The International Conference of Human Habitat**
- Participated in **NASA (National association of Student of Architecture)**inter-collegiate competitions.

CERTIFICATION

Licensed Architect

May 2023 - Dec 2032

The Council of Architecture

India

Registration ID: CA/2021/130352

Portfolio

Selected work
Academic & Built Projects
2019-2024

By an architect who practiced **architecture & interior design** for 2.5 years, passionate about model making, sketching, painting and everything construction!

By
Urvi Basu

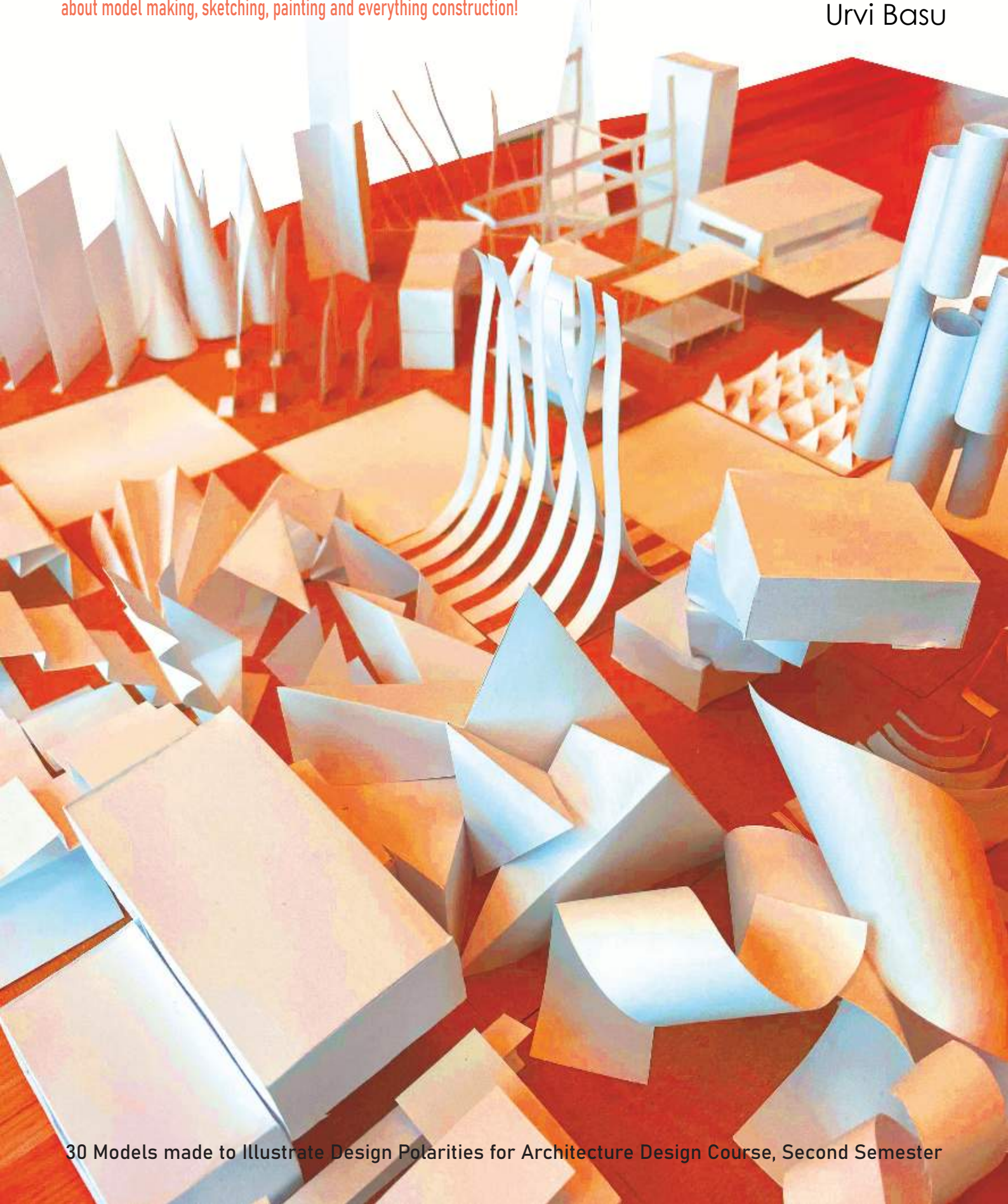

30 Models made to Illustrate Design Polarities for Architecture Design Course, Second Semester

2.5 Years of Professional Experience



Ar. Urvi Basu
Architectural Designer

Located in : New Jersey
Phone: +15513392926
Email Id: urvibas1@gmail.com
ub42@njit.edu
LinkedIn:
<https://www.linkedin.com/in/urvi-b-b7b5329b/t>

Technical Proficiency

Autodesk Revit | Autodesk Autocad
Rhinoceros 3d | Sketchup 3d
Adobe Photoshop | Adobe Illustrator
Lumion | Enscape
QGIS- Geographical Information Systems
Microsoft Office

Education

Master of Science in Architecture,
New Jersey Institute of Technology,
Hiller College of Architecture (HCAD)
Currently Pursuing 2nd Semester
Present since: Fall 2023

Bachelor's of Architecture,
Chembur Trombay Education
Society, College of Architecture,
Mumbai University
Bachelor's of Architecture
Graduated in 2020
Program duration: 5 Years

Licensed Architect, Council of
Architecture, India

Bio

Urvi Basu, a dynamic architectural wizard with over **two and a half years of practice**, draws inspiration from the world's beauty accompanied by her furry co-pilot, Rio. Beyond her architectural prowess, Urvi seamlessly integrates her passions for urban design, museum gazing, and architecture by painting, sketching, and illustrating. A tech-savvy and motivated architect, she transforms every canvas into a masterpiece. **Currently pursuing a Master of Science in Architecture at the New Jersey Institute of Technology**, she brings a dedicated and results-driven approach, honing her expertise through hands-on experience crafting exceptional designs for **hospitals, hospitality, and residential spaces in India**. **Proficient in project management and architectural design**, her commitment to excellence permeates every facet of her work. Eager to contribute innovative solutions and strategic thinking, she is poised to bring unparalleled creativity and expertise to elevate her organization's projects and goals, reflecting her vibrant and holistic approach to architecture.

Work Experience | Practical experience gained in Mumbai, India

- | | |
|--|--|
| Architect
August 2022-May 2022
Architecture & Interior
Residential & Commercial | Shahen Mistry Architects
<u>Design Project and Work Role</u>
Three residential projects, Luxury Villa, Office Project <ul style="list-style-type: none">Headed client meetings, planning, designing, executing, and coordinating projects in heritage buildings, focusing on structural repairs and damages, completed in 4-6 months. Collaborated with two architects to prepare a high-value conceptual design for a themed villa, including landscape, construction, supervision, and material selection for an environmentally friendly project. |
| Junior Architect
August 2021- January 2022
Interior Hospitality | Snow World Entertainment
<u>Design Project and Work Role</u>
Four themed Resto-bar and nightclub <ul style="list-style-type: none">Collaborated with a team of two architects and a principal designer to drive the following projects from conceptualization to completion. Led efforts in concept development, final design, construction drawings, material market study, bills of quantities, and on-site coordination for seamless execution. |
| Junior Architect
January 2021- August 2021
Architecture & Interior
Hospitals | Clancy Global
<u>Design Project and Work Role</u>
Nine Cloudnine Maternity Hospitals in pan India- 3.3 lakh Sq.ft <ul style="list-style-type: none">Prepared strategic planning and conceptualization, development of floor layouts, interior styling, material selections, client management, preparation of bills of quantities, creation of construction drawings and GFCs, on-site visits, team coordination, inspection, and overseeing final handovers. |
| Architectural Internship
August 2018- May 2019
Architecture
Residential & Commercial | Ingrain Architects
<u>Design Project and Work Role</u>
Market House, Garden, Club Complex, IKEA <ul style="list-style-type: none">Conceptual Stage development with initial strategies. |

Freelance Projects

- 3 BHK Apartment:**
Residential Interior Design, 1300 sq. ft approx. The total carpet area is designed.
- Dental Clinic:**
Commercial Interior Design, 675 sq. ft approx. The total carpet area is designed.
- 2.5 BHK Apartment:**
Residential Interior Design, 900 sq. ft approx. The total carpet area is designed.
- Living Room:**
Residential Interior Design, 250 sq. ft approx. The total carpet area is designed.

Publications | Urban Design Lab

- Makeshift Urbanism:**
<https://urbandesignlab.in/makeshift-urbanism-rekindling-the-underutilized-spaces-of-mumbai/>
- New Urbanism :**
<https://urbandesignlab.in/new-urbanism-perspective-on-urban-planning-of-singapore/>
- Recalibrating Living Dimensions of Heritage Sites:**
<https://urbandesignlab.in/recalibrating-living-dimensions-of-heritage-sites/>
- Dharavi – A city within a city:**
<https://urbandesignlab.in/dharavi-a-city-within-a-city/>

Contents

Academic (Masters & Bachelors Projects)

1. Landesgalerie,Krems,Austria, Urban Design Studio,Semester 1, M.s. in arch
2. Reversing the anthropogenic impacts of a faithscape, Design dissertation, B.arch
3. Underground Metro line-3 precinct area development, Semester 9, B.arch

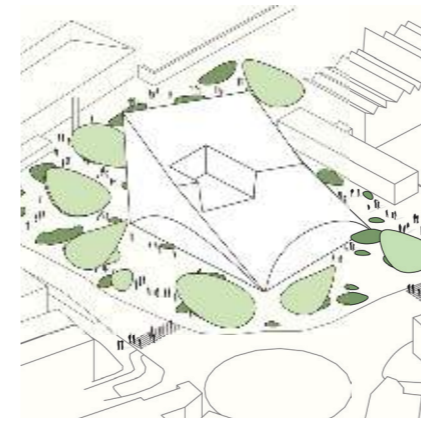

01



02

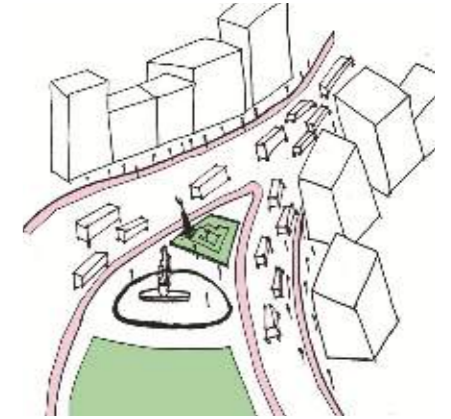

03

Professional Practice: Built Projects (2021-2023)

4. Luxury villa, alibaug,Architecture, Residential India
5. Rustom baug apartments, Interior,Residential, India
6. Game palacio,Nightclub,Hospitality,Interior,India



04

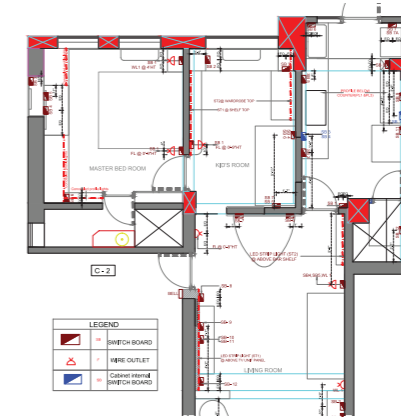

05



06

Freelance Projects: Built Projects (2022-2023)

7. 3BHK Apartment,Ruby, Interior,Residential, India
8. Dental clinic,Commercial,Interior,India



07



08

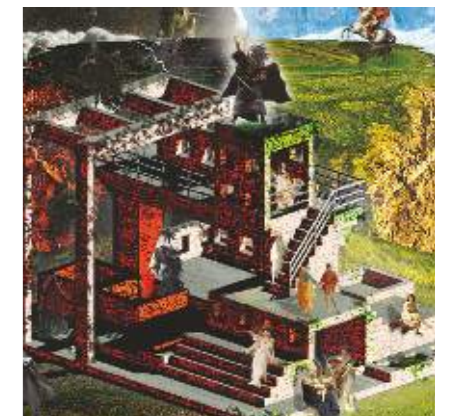

09

Miscellaneous

- 9a. Renders and Illustrations
- 9b. Publications
- 9c. Paintings & Model Making

Academic

Landesgalerie, Krems, Austria

Year: 2023

Work Type: Group project

Course: Urban Design Studio, Semester 1, M.S. in Architecture

Role: Conceptualization to final design output.

Softwares used: Rhinoceros 3D, Adobe Illustrator, Adobe Photoshop,

Midjourney, PowerPoint presentations, QGIS.

The project involved a comprehensive analysis and redesign of the precinct area surrounding the existing Landesgalerie in Krems, aiming to establish a seamless connection to the Kunstmeile. An initiative to redevelop the precinct that connects more than 20 art venues along the Kunstmeile (art mile), in Krems, Austria, our design concept focused on the removal of the existing asphalt around the museum, replaced by the creation of an urban forest to enhance the overall green coverage. To catalyze an increase in visitors and foster stronger connections between artists and the public, we strategically incorporated various urban machines, introducing new programs to the museum site. This approach not only revitalized the space but also stimulated a dynamic growth in both the artistic community and visitor engagement.

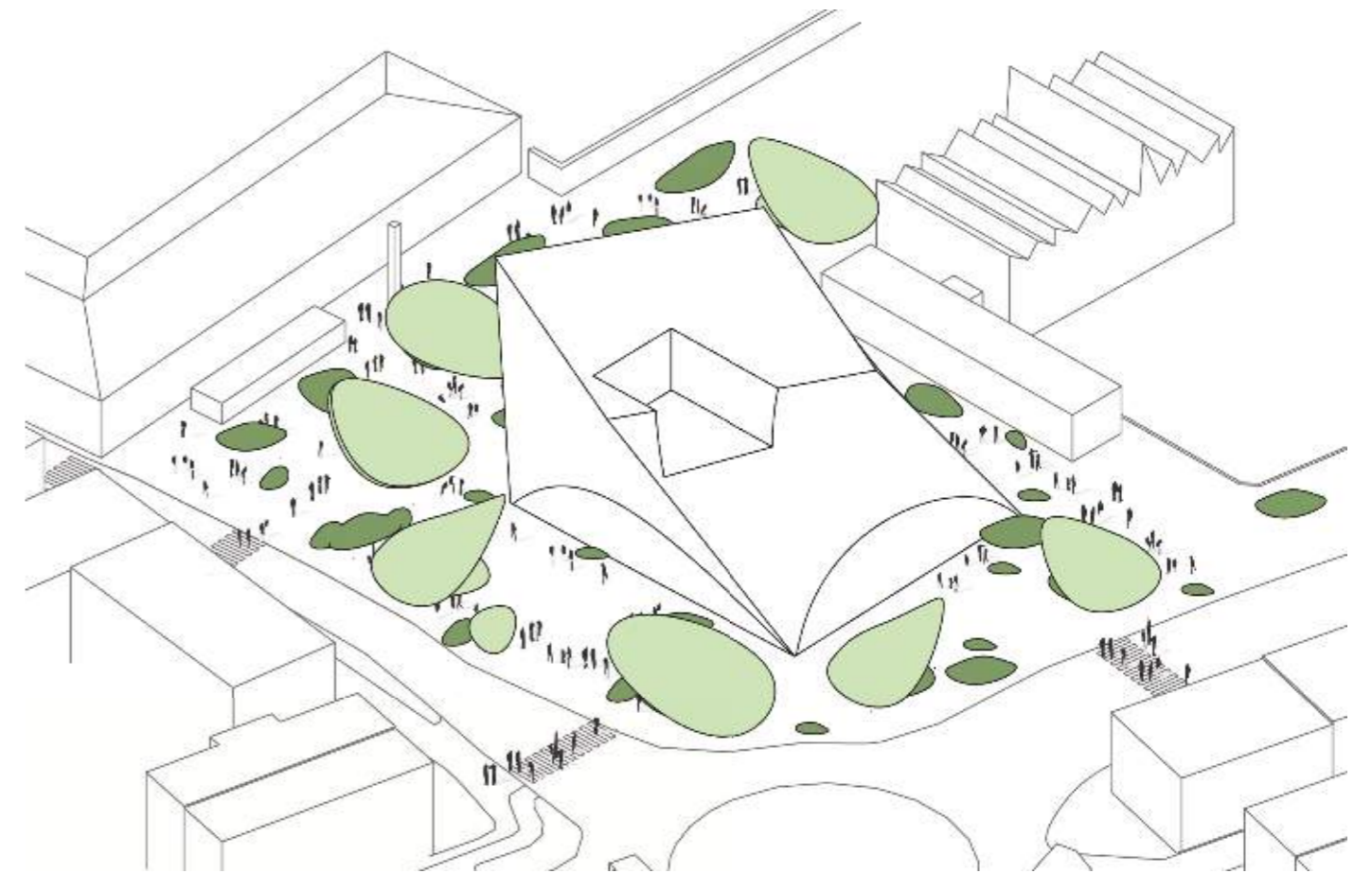

Axonometric View

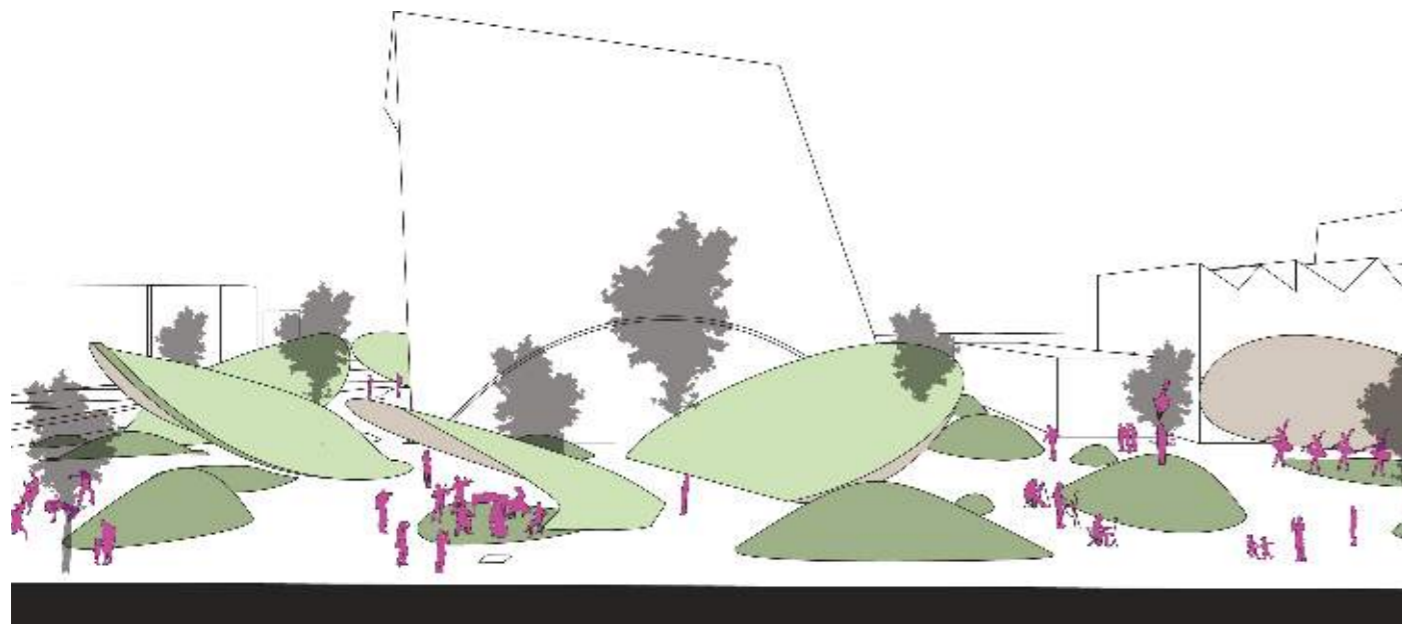

Elevation



Site Plan



Discussion Pods designed as natural mounds/shells to act as multi functional space for museum.

Urban Machines

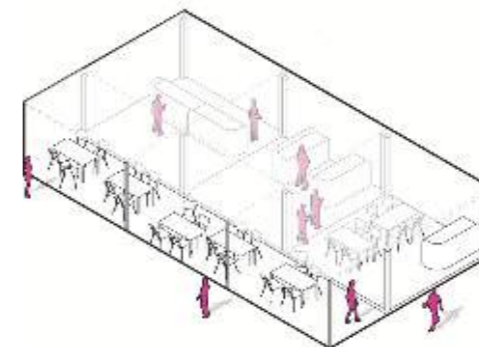

Local Artist Market Pods

A modular space to promote local artists through market style exhibition space.

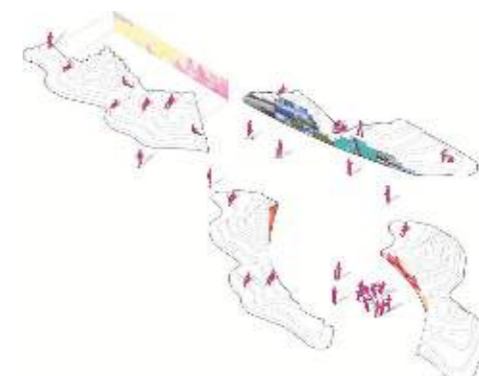

Multi-purpose mounds

Used to disrupt the landscape while providing either shelter or seating for the public.



Outdoor art installations

Devices which shift the landscape through visual effects prompted from various installations.

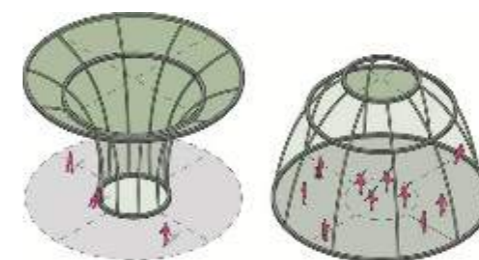

Discussion Pods

Parametric structures which act as a shading devices or enclosed pods for multipurpose programs such as: speeches, performances, art exhibit

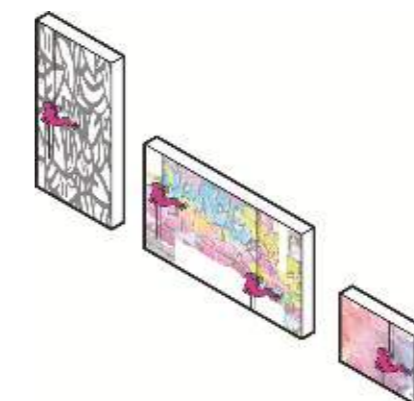

Rappelling (painting experience)

Walls extruded at different height to let people rappel and paint on it.

Academic

Reversing the anthropogenic impacts of a faith-scape

Year: 2020

Work Type: Design Dissertation/Thesis

Course: Architectural Design, Semester 10, Bachelor's of Architecture

Softwares: Autocad, Photoshop, 3d Sketchup, Lumnion, Indesign

The peri-urban region of Vajreshwari-Akloli unfolds a vibrant landscape with rich historical and religious significance, nestled within the delicate ecosystem of the Tansa River and geothermal activities. Unfortunately, the area has experienced a **decline due to various tourism-related impacts**. The research aims to raise awareness among the public by leveraging religious understanding and promoting a substantial reduction in the carbon footprint through an eco-sensitive design. The focus of the study is on comprehending different facets of **mitigating anthropogenic effects through sustainable approaches** while preserving and respecting existing religious practices.

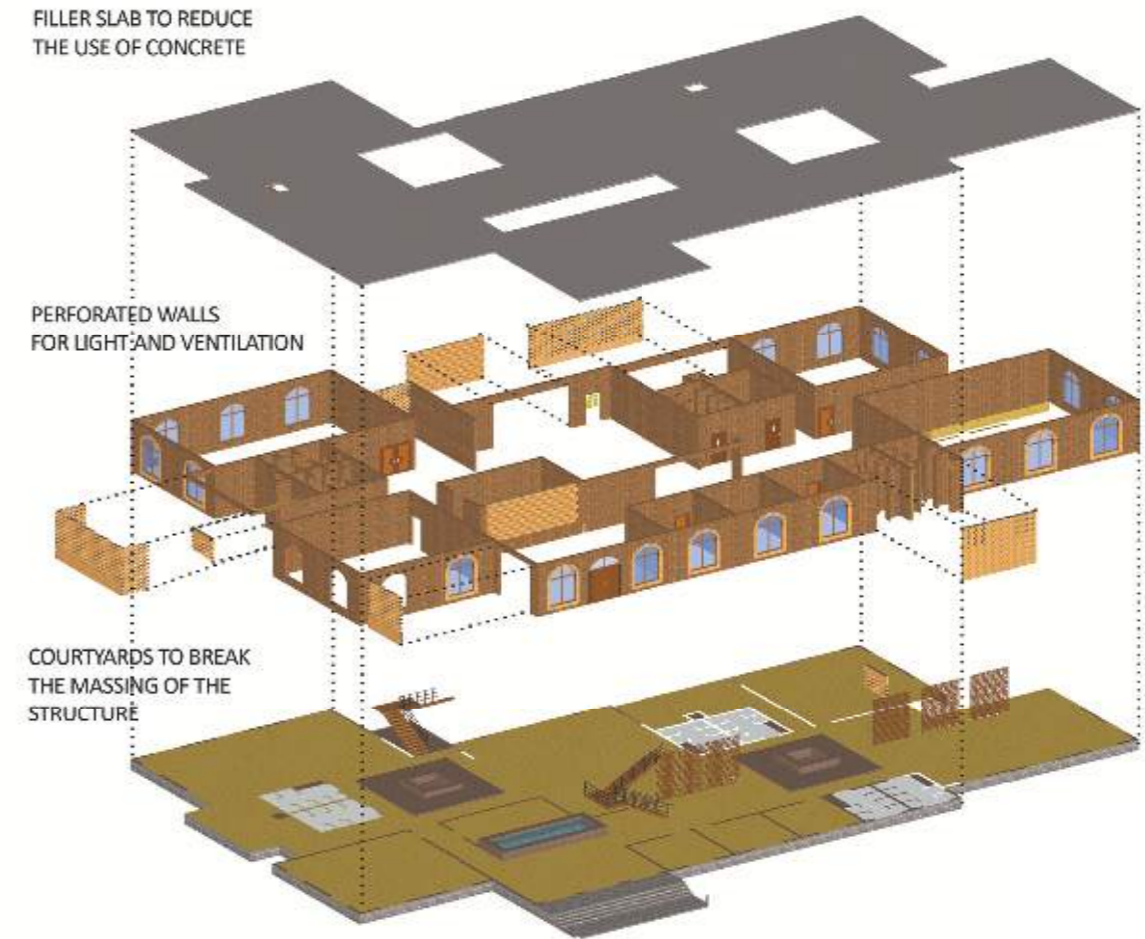

Exploded Structural System



Dormitory Elevation

ACCESS



VOID



WORDPLAY



ENTRY POINTS

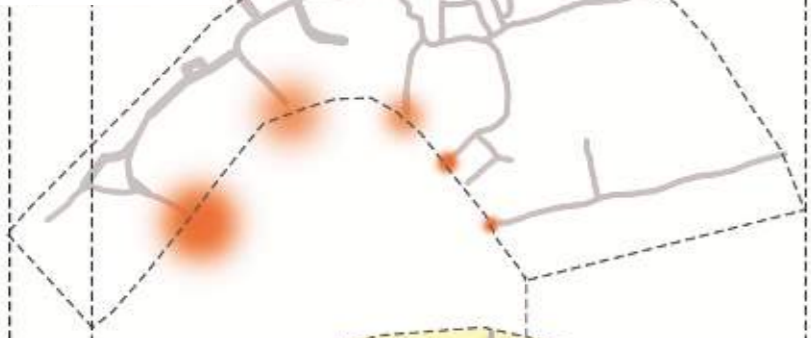

COMPLEXES

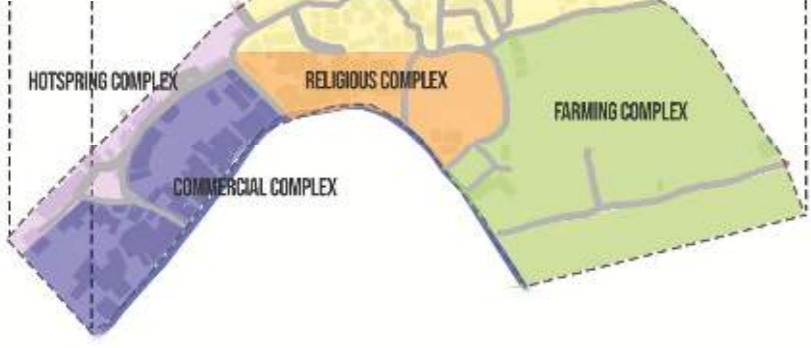

Site Plan

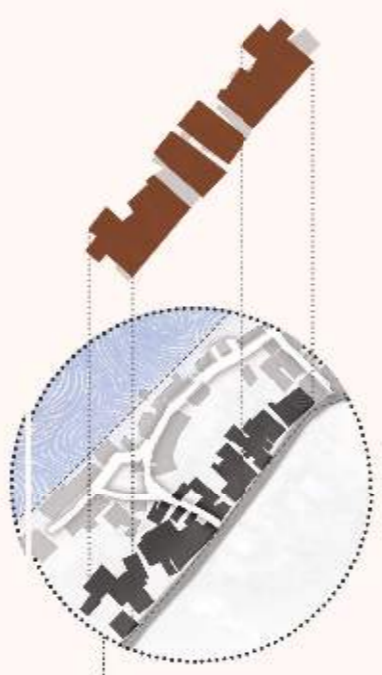

Commercial Complex



Hot spring Complex

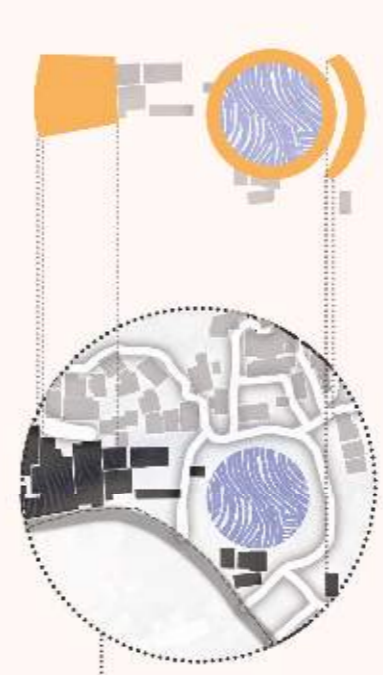

Religious Complex

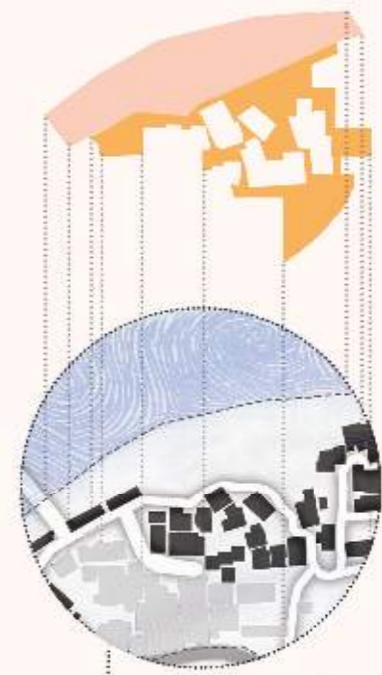

Residential Complex



Productive Farming Complex

Academic

Underground Metro line-3 precinct area development in Mumbai, India

Year: 2019

Work Type: Group

Course: Architectural Design, Semester 9, Bachelor's of Architecture

Softwares: Autocad, Photoshop, 3d Sketchup, Lumion.

In the fort precinct of Mumbai, India, open public spaces play a vital role in determining the planning of the area. But due to the population growth these **spaces endanger encroachment**. **The design aim at revitalizing these urban spaces by using the references of the past and establishing spaces to pause-breathe -walk**. The design also aims at initiating **collaboration between the city, its citizens, institutions and programs** to encourage public transportation and move apart from a chaotic commutation scenario.

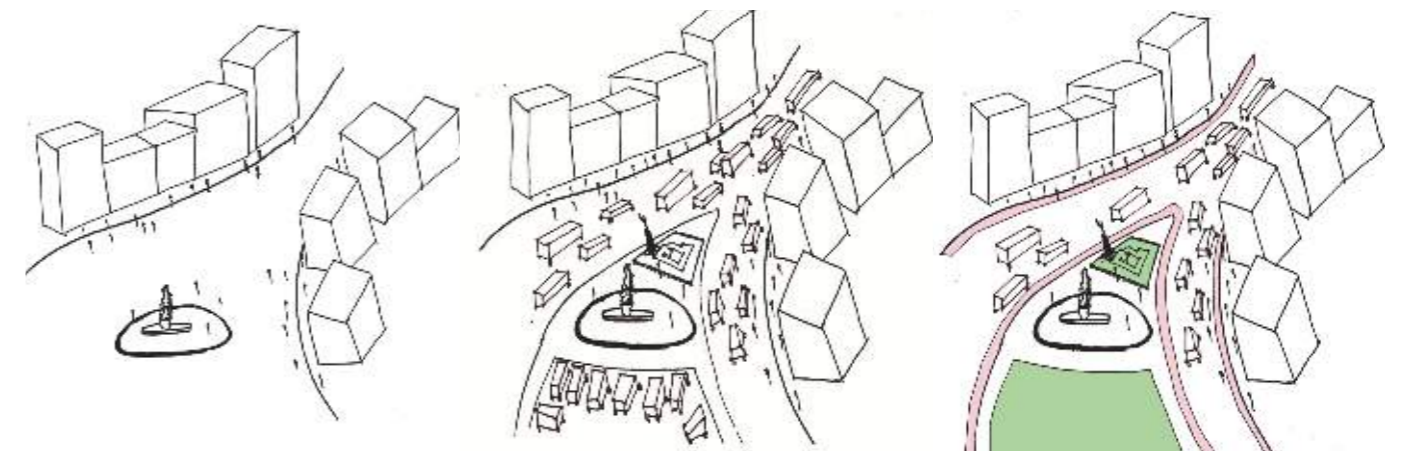

Openness in the past

Transportation boost in the area led to encroachment

Reviving & revitalizing open spaces



Bird eye view



Garden view



Professional Practice

Luxury Villa-Alibaug, India

Year: 2023

Work Type: Group at Shahn Mistry Architects

Professional Designation: Architect

Softwares : Autocad, Photoshop, Microsoft Office

Job Role: Collaborated with two architects to prepare a high-value conceptual design for a themed villa, including landscape, construction, supervision, and material selection for an environmentally friendly project.

Project Status: Incomplete

The project was conceived to fulfill the client's vision of a modern and luxurious weekend home, featuring a building structure that seamlessly connects to a spacious swimming pool and deck area. Our design approach incorporated trees within the structure, along with wide, elongated terraces and balconies. In my role, I conducted initial client meetings, curated vision boards, documented the site, and coordinated with structural and MEP teams. Throughout the project, I gained valuable insights into sewage systems, rainwater harvesting, structural systems, and the overall process of construction from its initial stages.

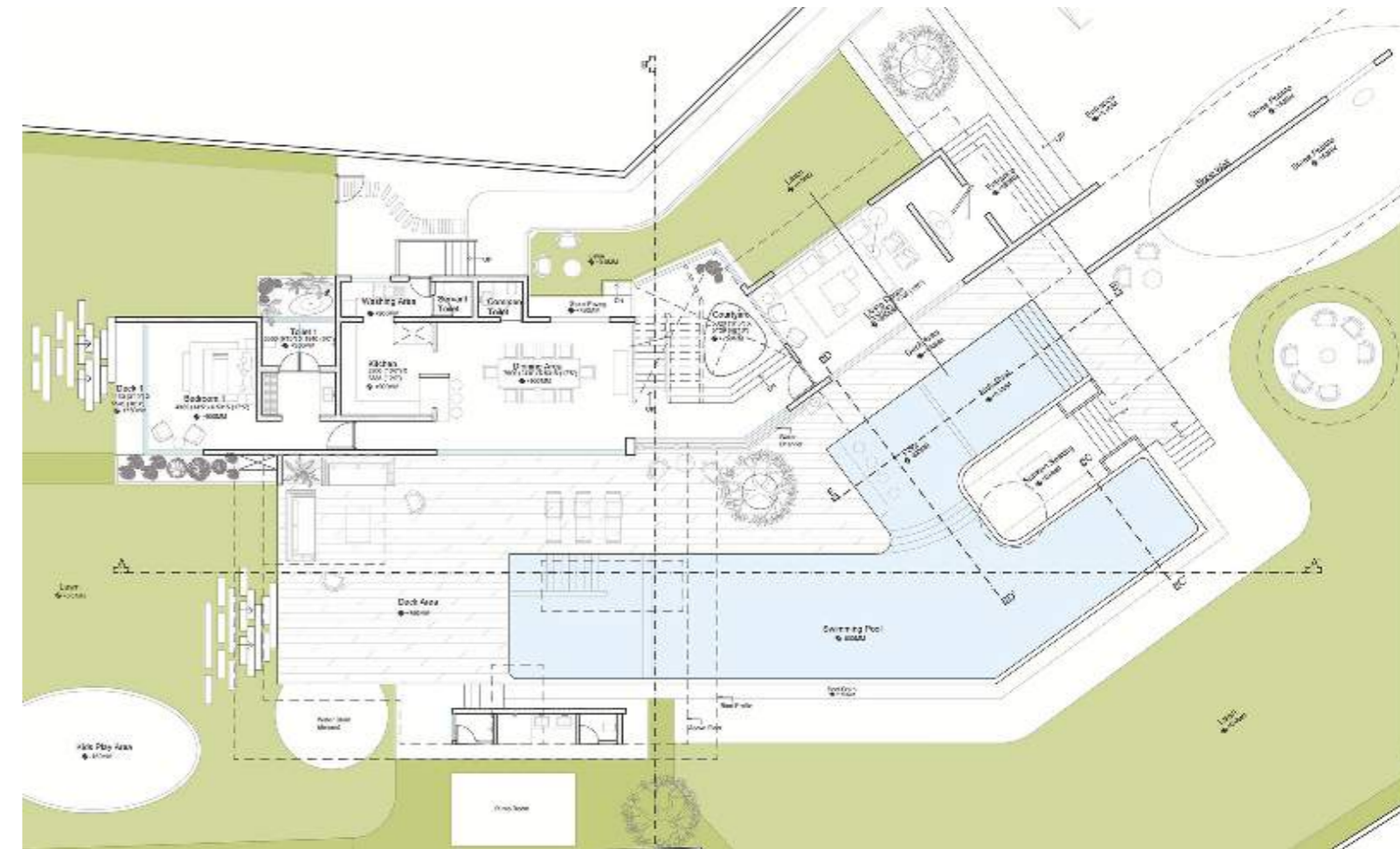

Ground Floor Layout

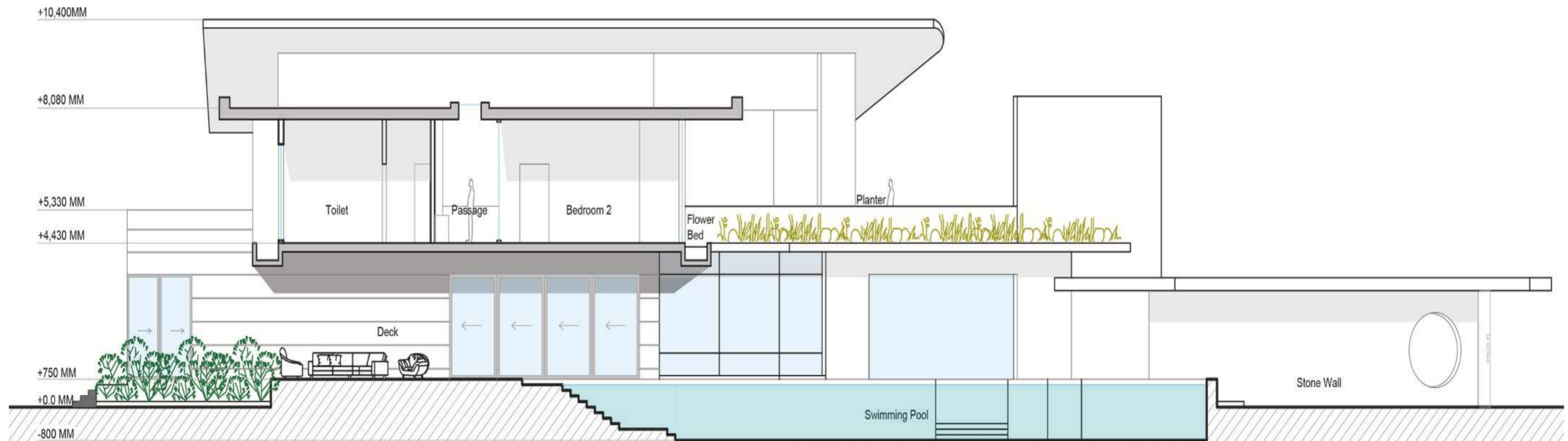

Section



Site Plan

Rendering made to present it to the client and Construction Teams



On site Development of first floor, also one can view grid slab construction.



Framing and reinforcement procedures

Professional Practice

Rustom baug apartments, Interior, Residential, India

Year: 2023

Work Type: Group work at Shahn Mistry Architects

Professional Designation: Architect

Softwares: Autocad, Photoshop, Microsoft Office

Job Role: Headed client meetings, planning, designing, executing, and coordinating projects in heritage buildings, focusing on structural repairs and damages.

Project Status: Complete

The design aimed to achieve a minimalist yet contemporary aesthetic. The clients desired a home characterized by white walls and subtle pastel tones. Converting a pre-existing 2.5bhk into a 3bhk apartment to include a kid's room was a key aspect of the project. Despite being a low-budget interior design endeavor, afford-ability was prioritized throughout. The addition of moldings and amber chandeliers enhanced the overall space, lending it a touch of sophistication and class.



A 3D view was generated to present to the client during the initial conceptual stages.

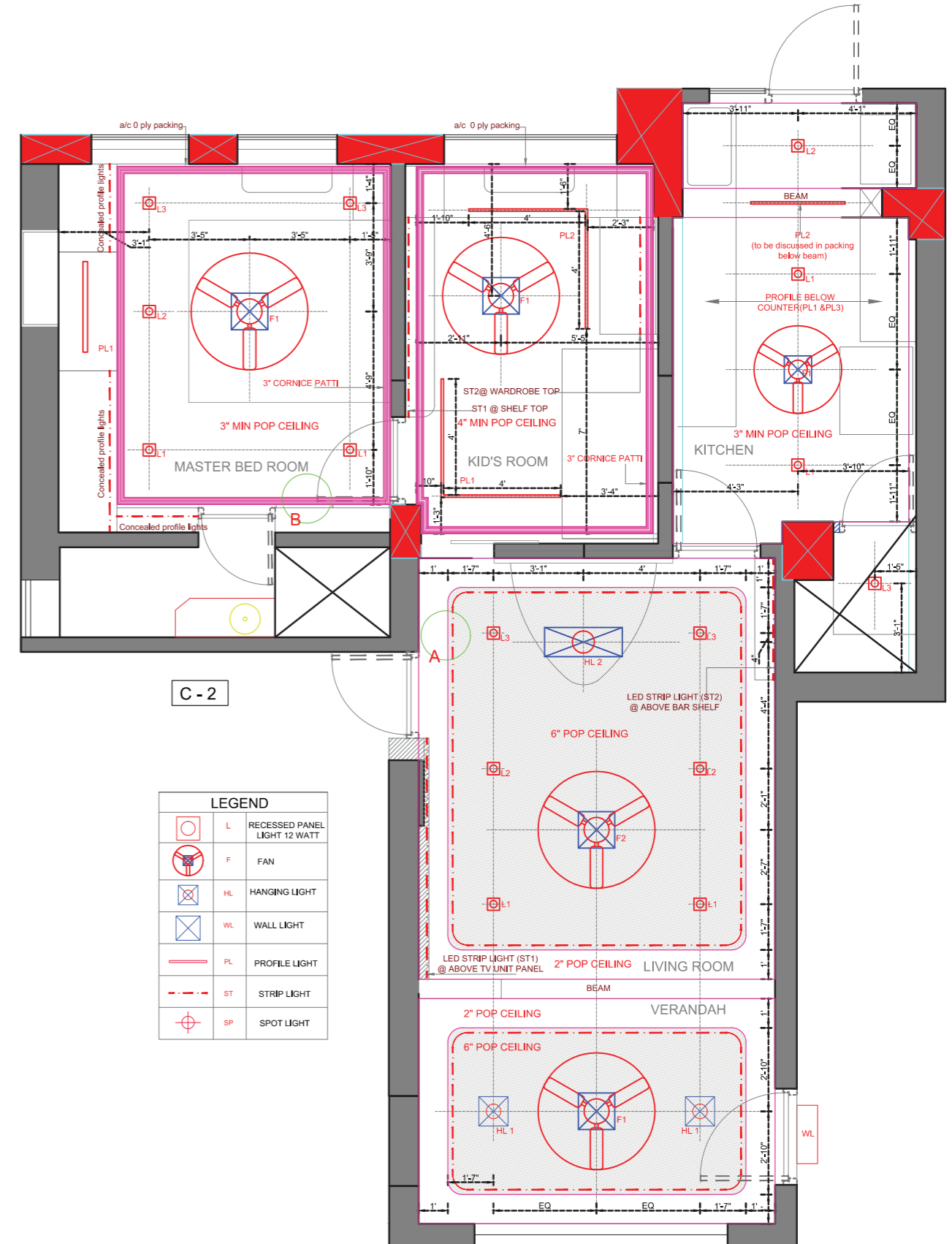

Furniture Layout

Designing the washroom presented a challenge due to its narrow width and elongated shape. Careful consideration was given to safety and ease of movement, especially considering it would also be accessed by children.

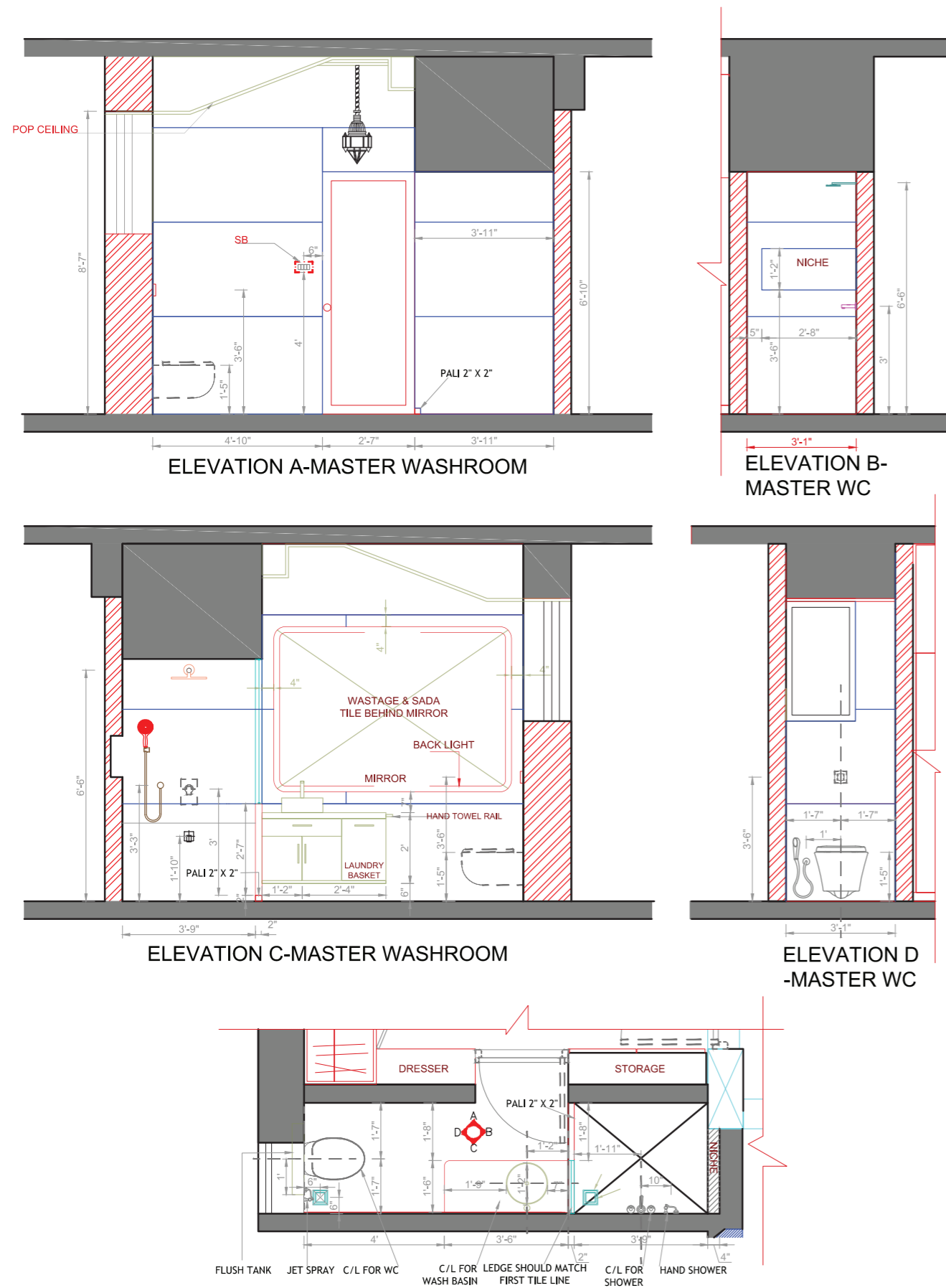

The Arched Mirror adds a sense of grandeur to the living room, creating the illusion of more space and inviting in additional daylight to brighten the expansive living area.



The addition of a pop of green in the foyer space not only infuses warmth into the living area but also introduces elements of Parsi traditional aesthetics. This combination makes the space a delightful area to enjoy while gazing out the window.



The mirror was positioned within the expansive wardrobe space, taking Vastu directions into account. It's carefully placed to ensure it's not visible from the sleeping area, meeting the client's request for a spacious dressing area while maintaining balance in the room layout.

Professional Practice

Game Palacio, Nightclub, Hospitality, Interior, Inida

Year: 2021

Work Type: Group at Snow World Entertainment

Professional Designation: Architect

Softwares : Autocad, Photoshop, Microsoft Office

Job Role: Collaborated with a team of two architects and a principal designer from conceptualization to completion. Led efforts in concept development, final design, construction drawings, material market study, bills of quantities, and on-site coordination for seamless execution.

Our vision was to bring together glamour and playfulness, merging contemporary clubbing with retro fun at Game Palacio, a pioneering hybrid nightclub in India. It caters to every weekend indulgence, offering a blend of family-friendly entertainment and quality cocktails. Despite the seemingly unconventional combination, Game Palacio seamlessly integrates these elements, creating a unique and immersive experience. From bespoke transparent bowling lanes to lavish gold accents against a velvety black backdrop, every detail is meticulously designed to enhance the venue's aesthetic appeal and ambiance.



Entrance Facade of The Game Palacio



Bar View

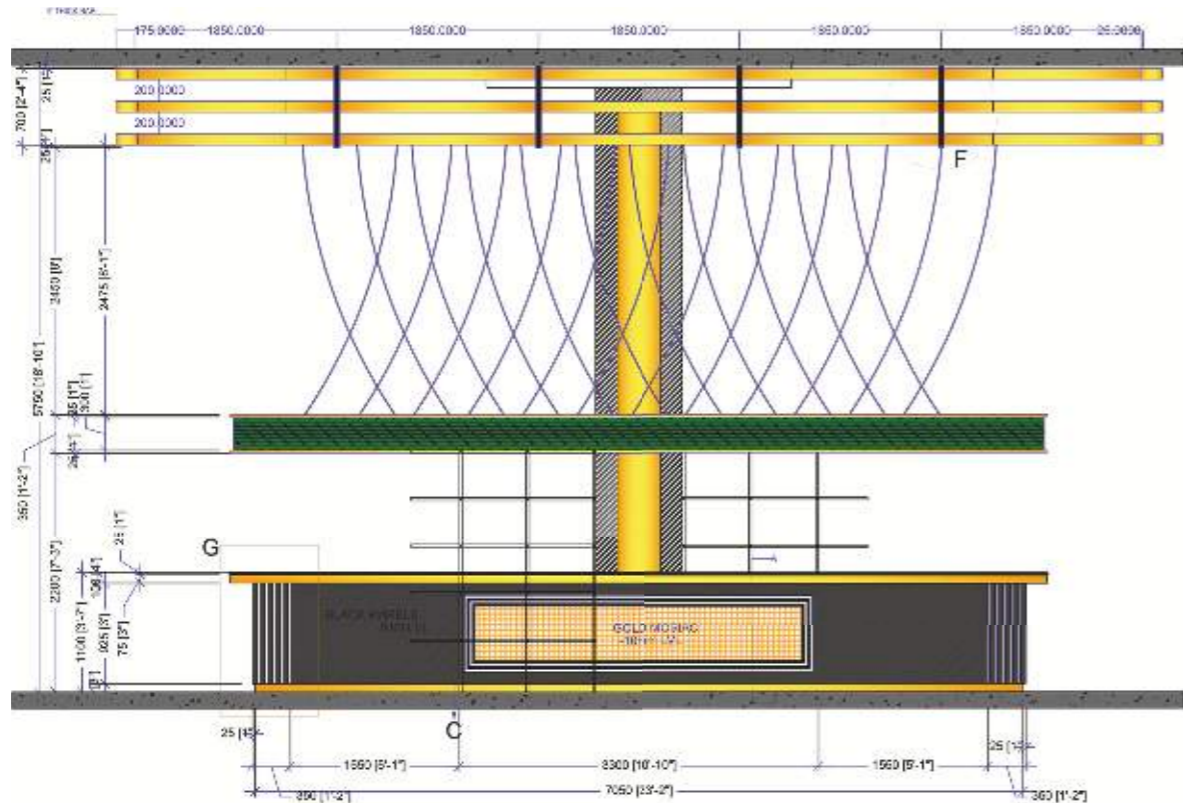

Bar Side Elevation

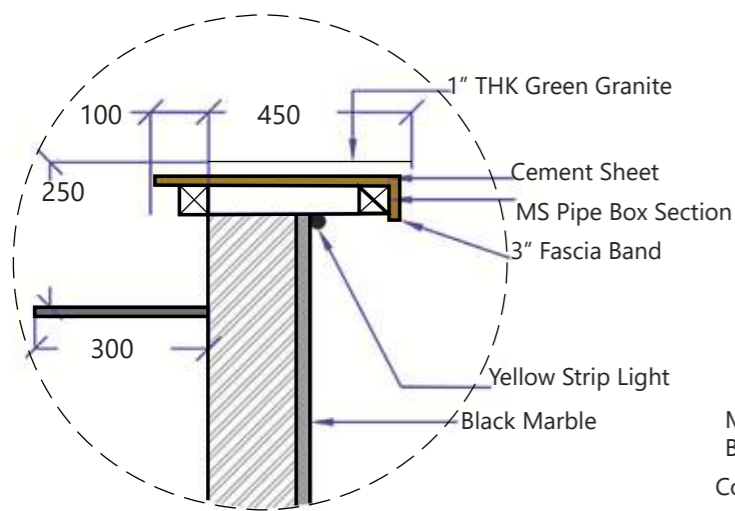

Fascia Detail at G

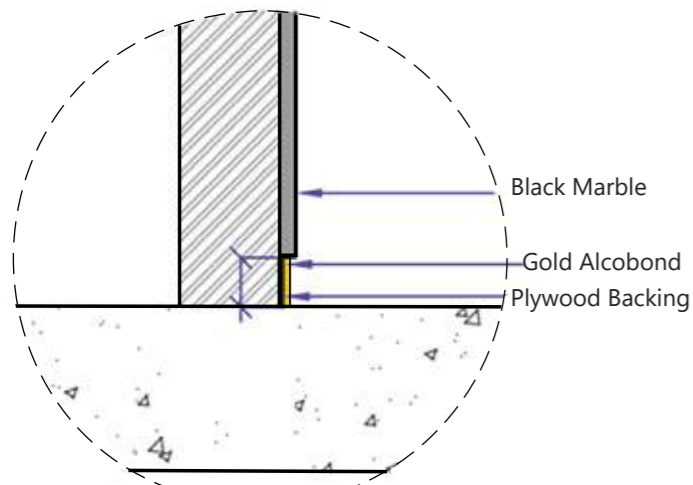

Skirting Detail at C

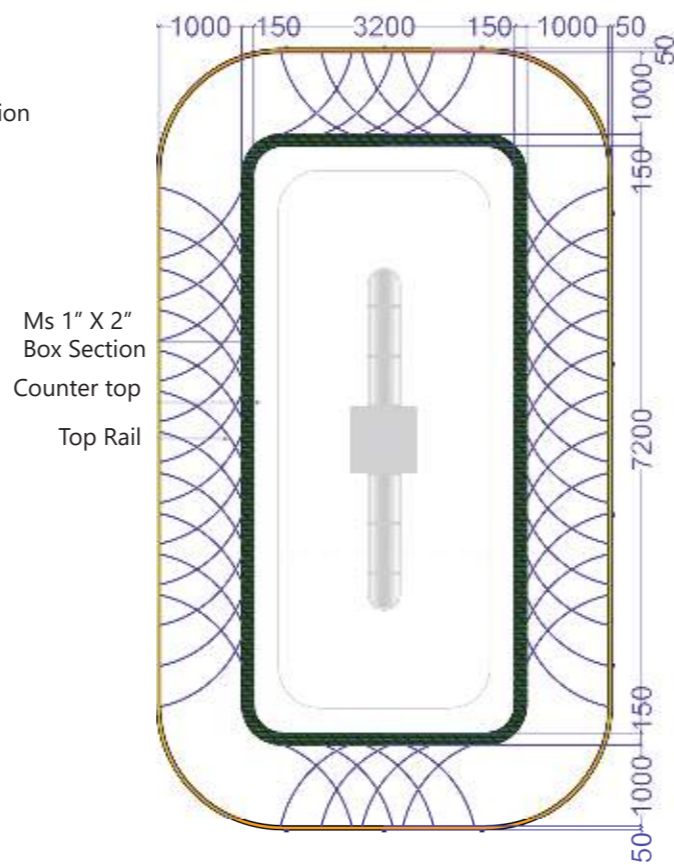

Bar Top Layout

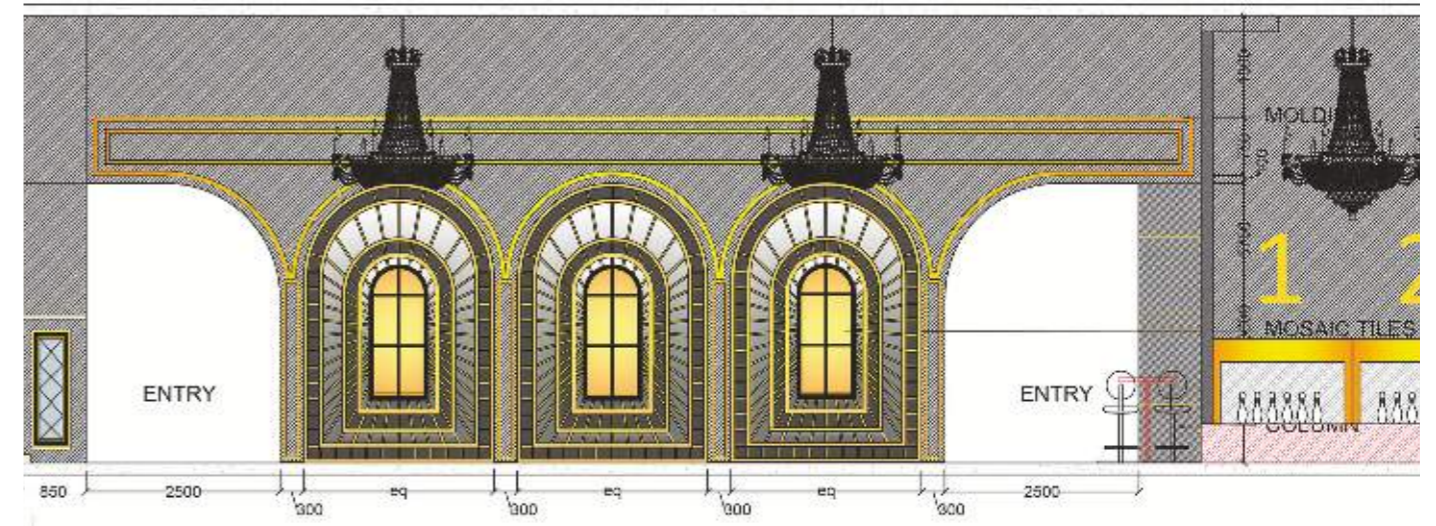

Wall-B Elevation

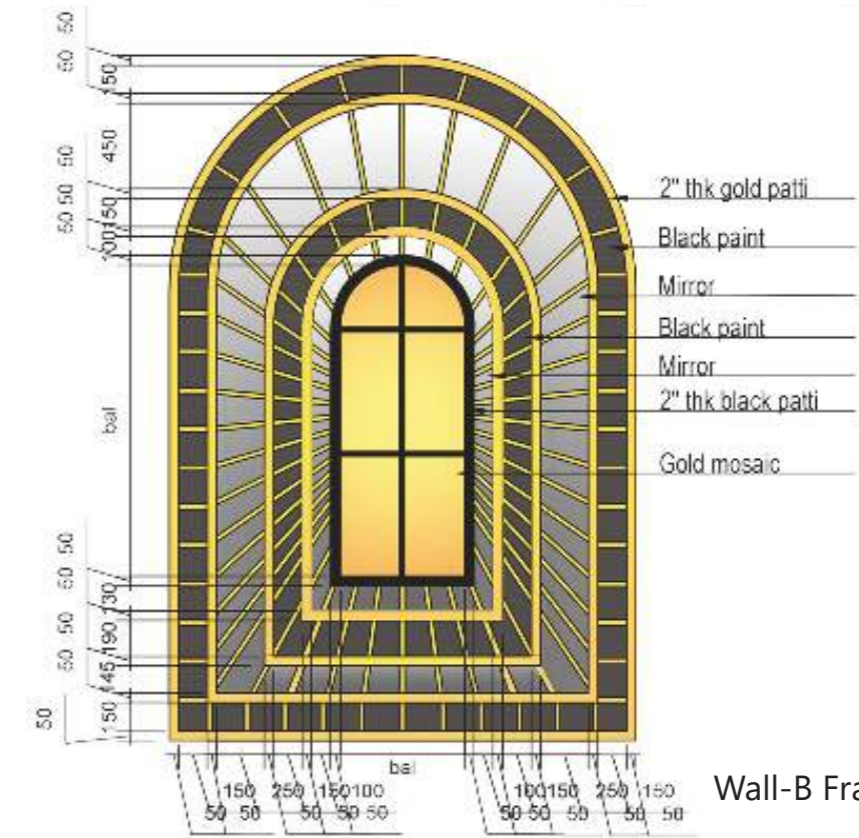

Wall-B Frame Detail

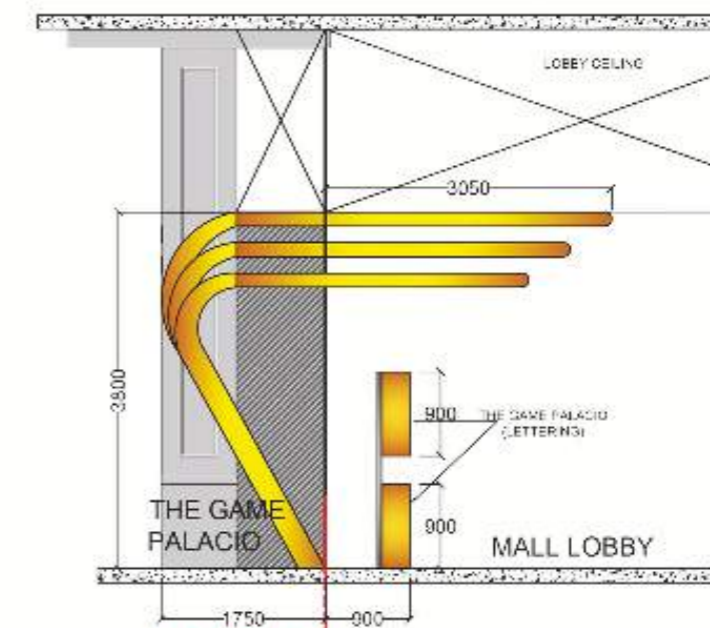

Mall Entrance Section

Freelance Projects

3BHK Apartment, Ruby, Interior, Residential, India

Year: 2023

Work Type: Individual Interior & Execution

Professional Designation: Project Architect

Softwares : Autocad, Photoshop, 3d Sketchup, Lumion, Microsoft Office

Job Role: As a freelance Architect, I collaborated closely with clients to conceptualize and implement innovative interior spaces that balance functionality and aesthetics. Responsibilities include client consultation, conceptualization, space planning, material selection, 3D visualization, project management, collaboration with stakeholders, documentation, and client communication.

Project Status: Complete

This budget-friendly interior project was tailored for an elderly couple seeking to transform their space into a safe, accessible, pleasant, and functional environment. The kitchen was expanded to include a cozy sitting area with added storage, maximizing the floor space. For the Master Bedroom, the focus was on achieving a classy and bright ambiance, achieved through the use of neutral tone palettes and molding bands to enhance the aesthetic appeal. A refreshing pop of mint green accents throughout the house, complemented by walnut wood-colored flooring, adds warmth and character to the space.



Master Bedroom View



Laminate selection for Wardrobe



Reusing Old Wardrobe and extending it



Reusing Old Wardrobe and extending it

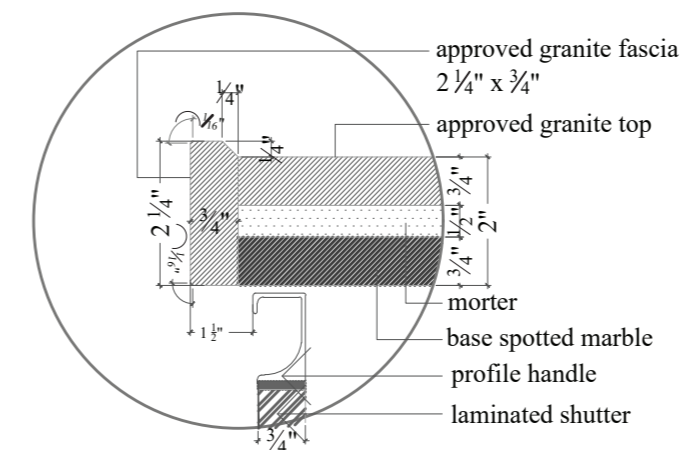

Counter Edge detail

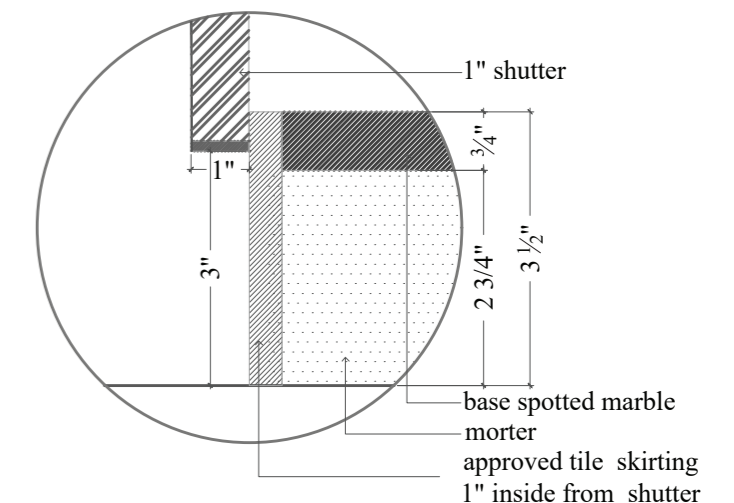

Skirting Detail

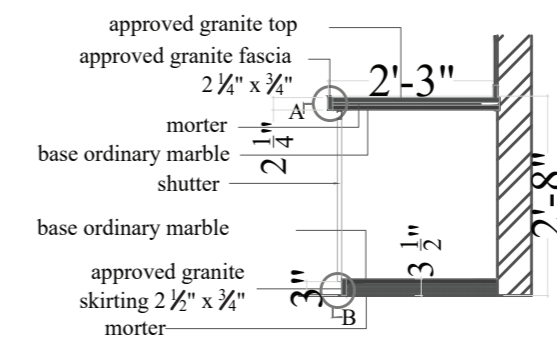

Platform Counter Section

Kitchen

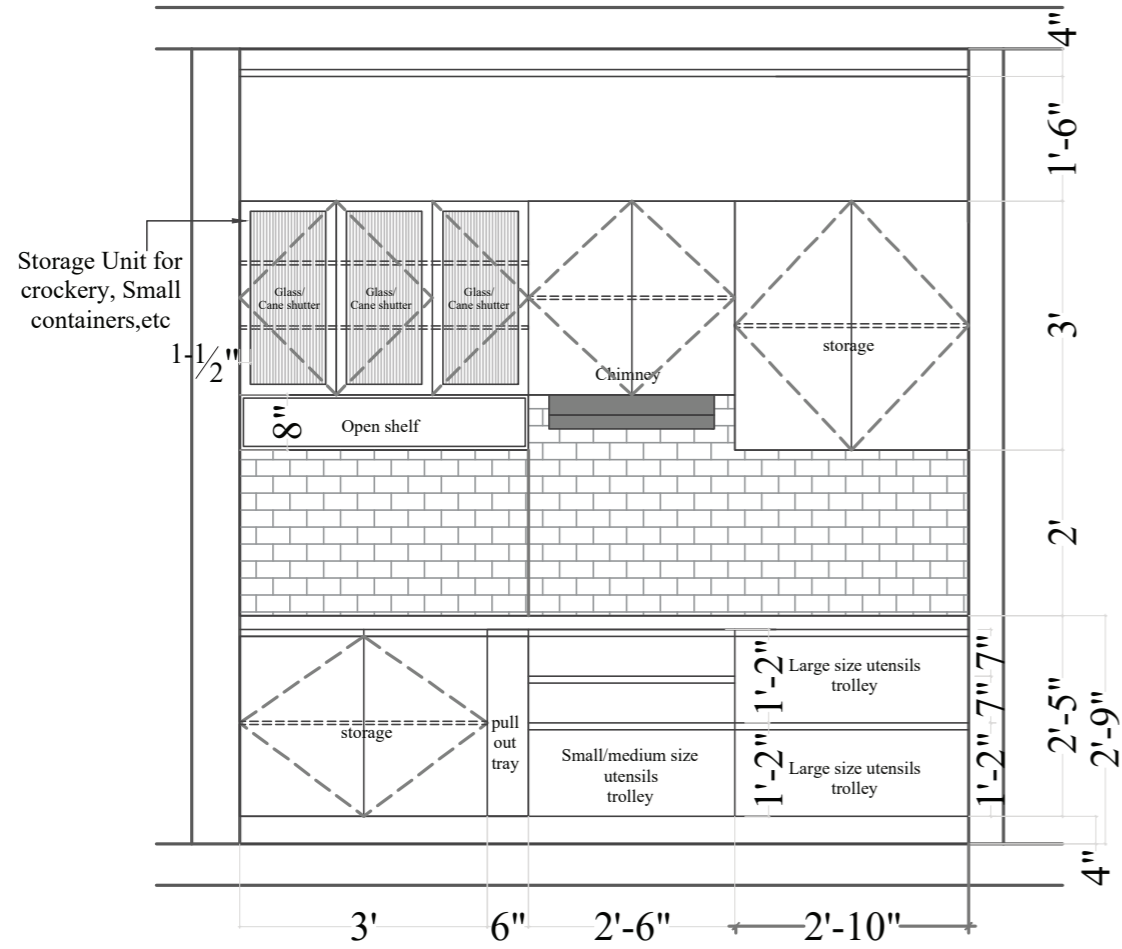

Section A-A

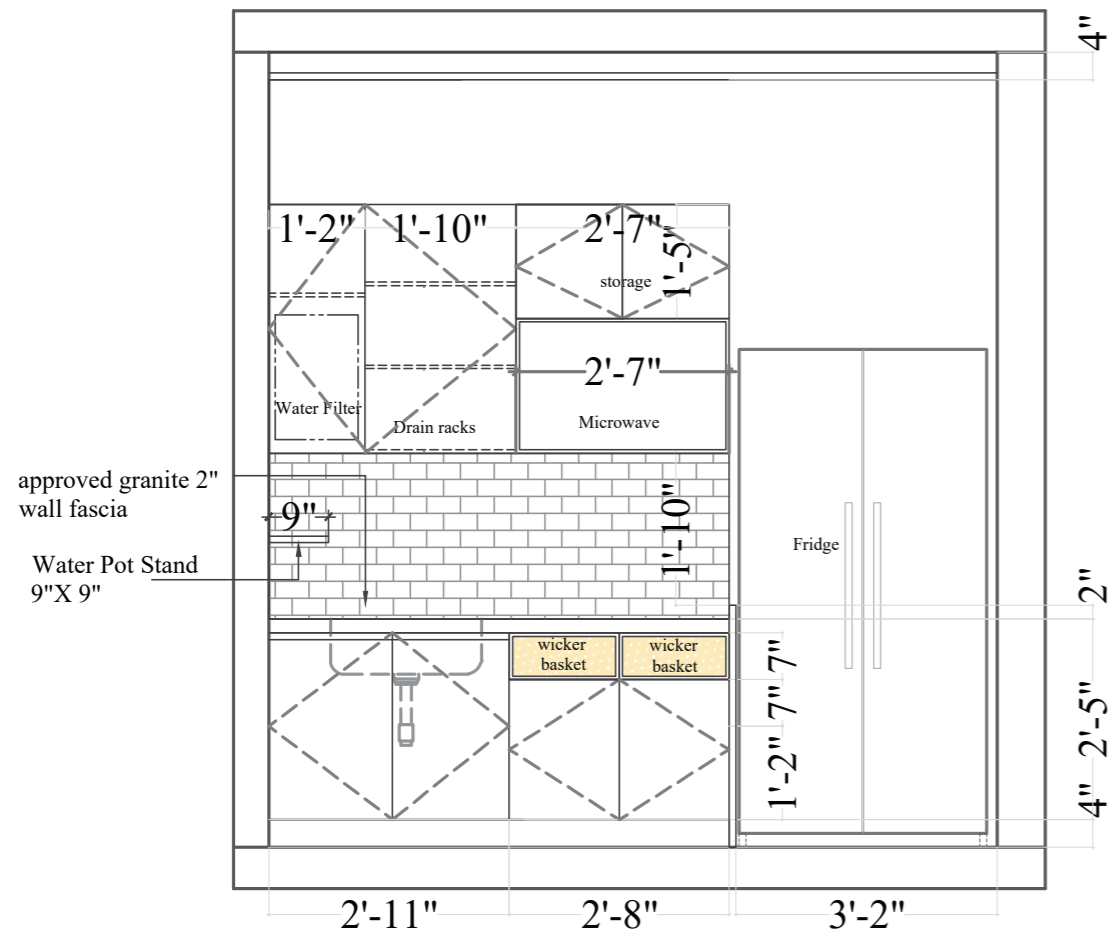

Section B-B

Main Door

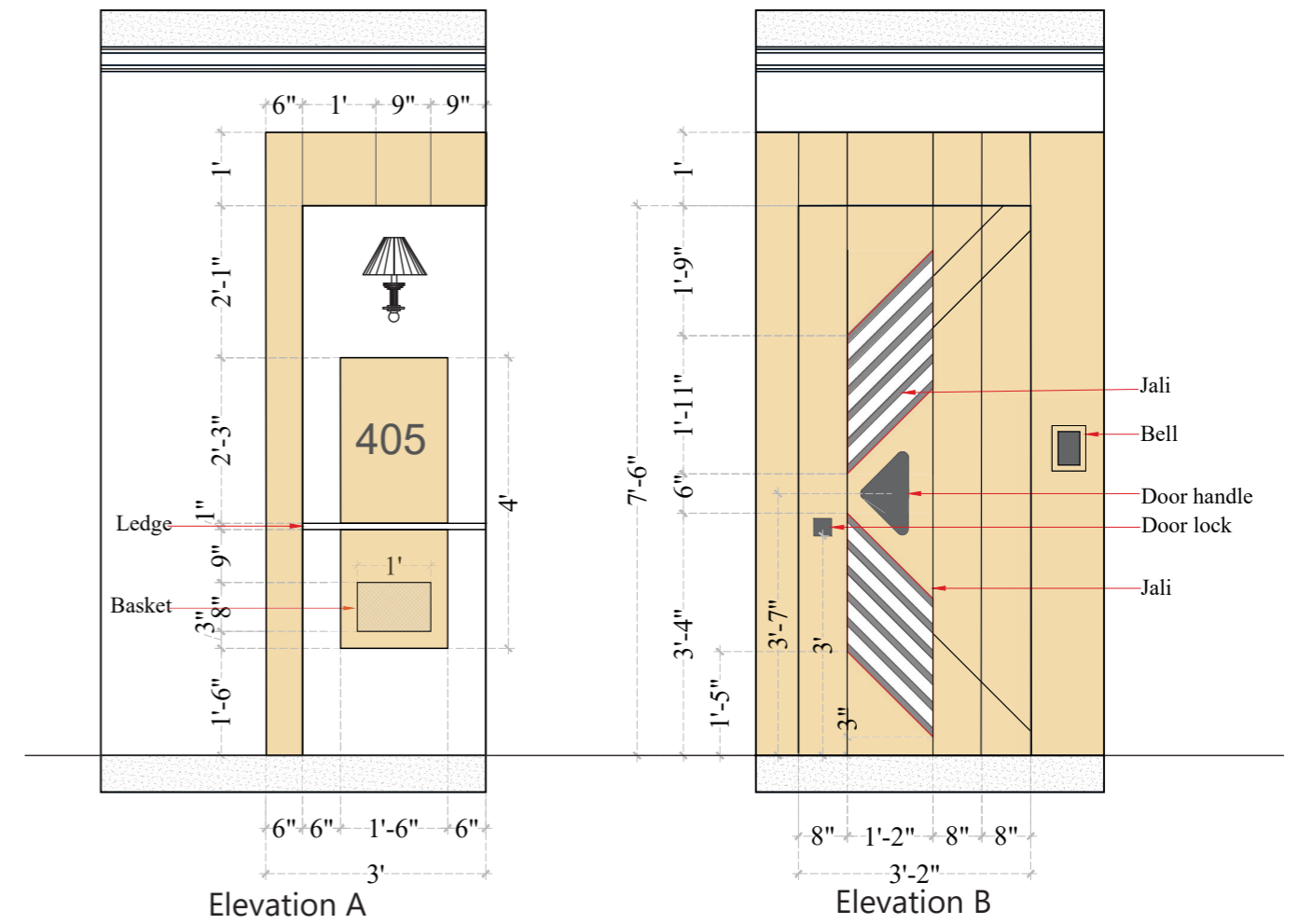

Elevation A

Elevation B



Freelance Projects

Dental Clinic, Commercial, Interior, India

Year: 2022

Work Type: Individual Interior & Execution

Professional Designation: Project Architect

Softwares : Autocad, Photoshop, 3dSketchup, Lumion, Microsoft Office

Job Role: Responsibilities include client consultation, conceptualization, space planning, material selection, 3D visualization, project management, collaboration with stakeholders, documentation, and client communication.

Project Status: Complete

The client's vision was to create a lively and energetic space with positive vibes. I achieved this by designing a minimalist layout and opting for muted beige and white tones on the walls. Strategic use of accent walls added a playful touch to the Dental Clinic, enhancing the overall experience. The project involved a complete transformation of the previous cafeteria space, with renovations from flooring to ceilings.



Waiting Area



Operational Zone of the Clinic

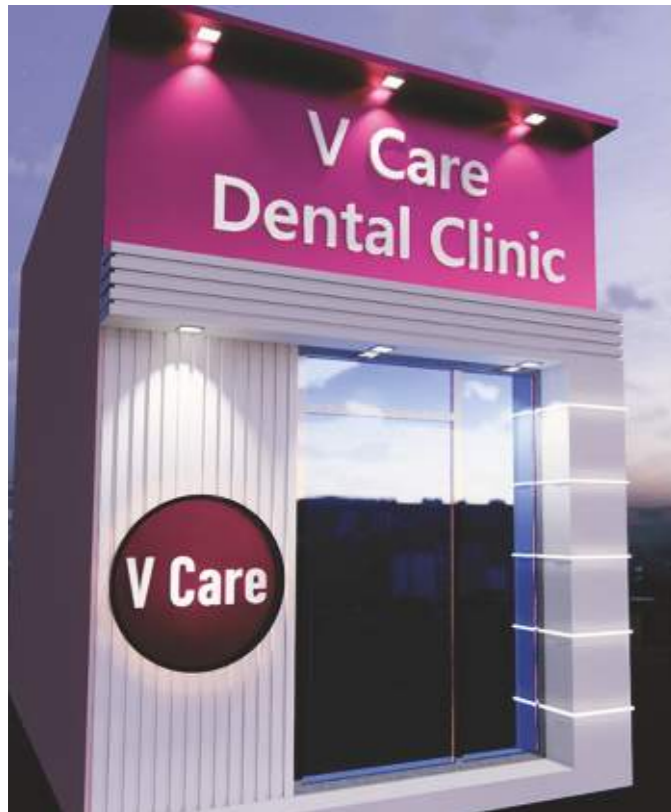

Front Facade 3D Conceptual View

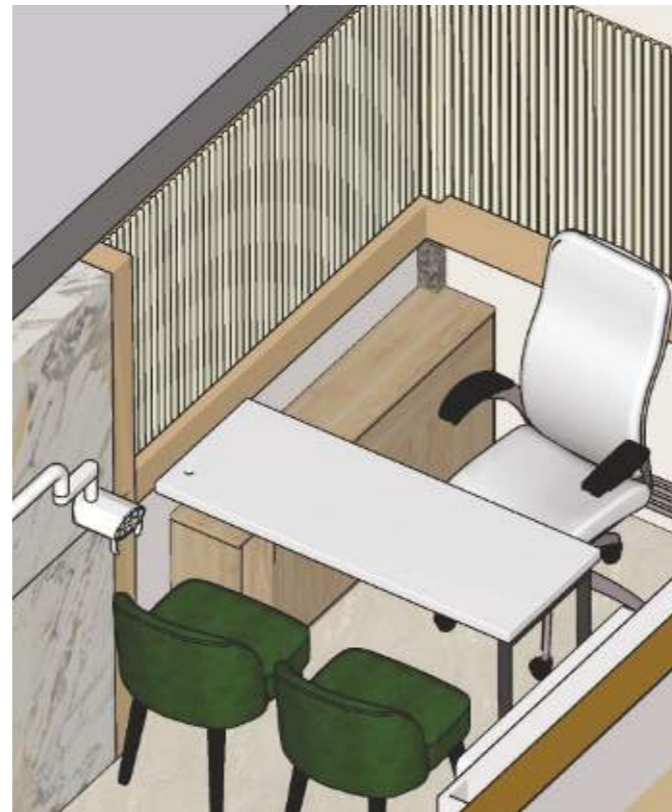

3D view on consultation desk area



Dentist's Consultation Desk

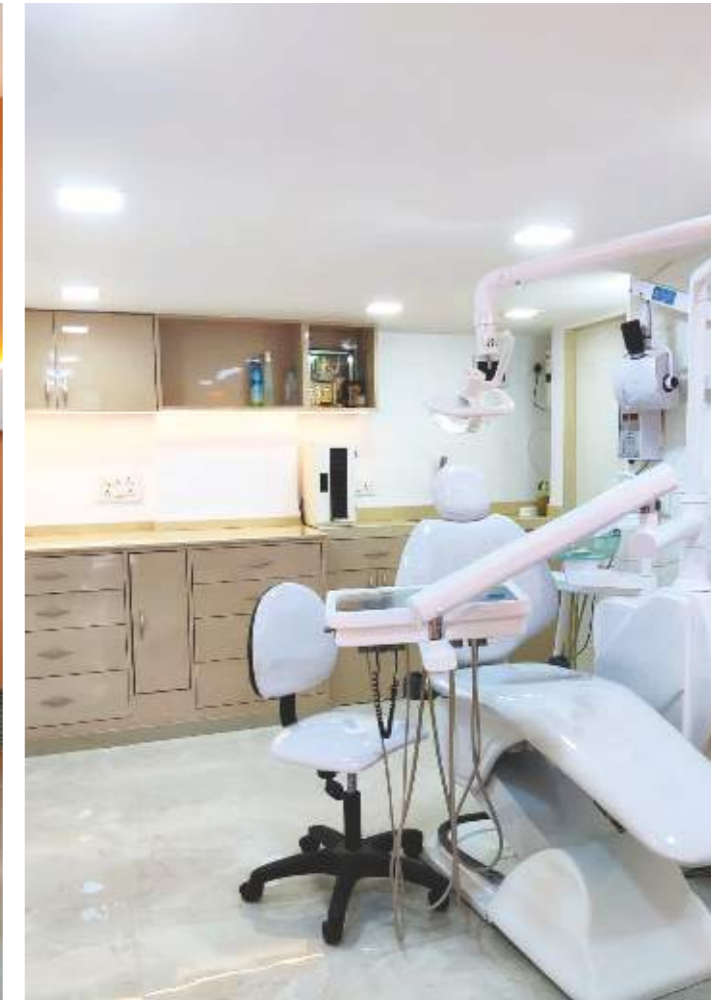

Treatment Area

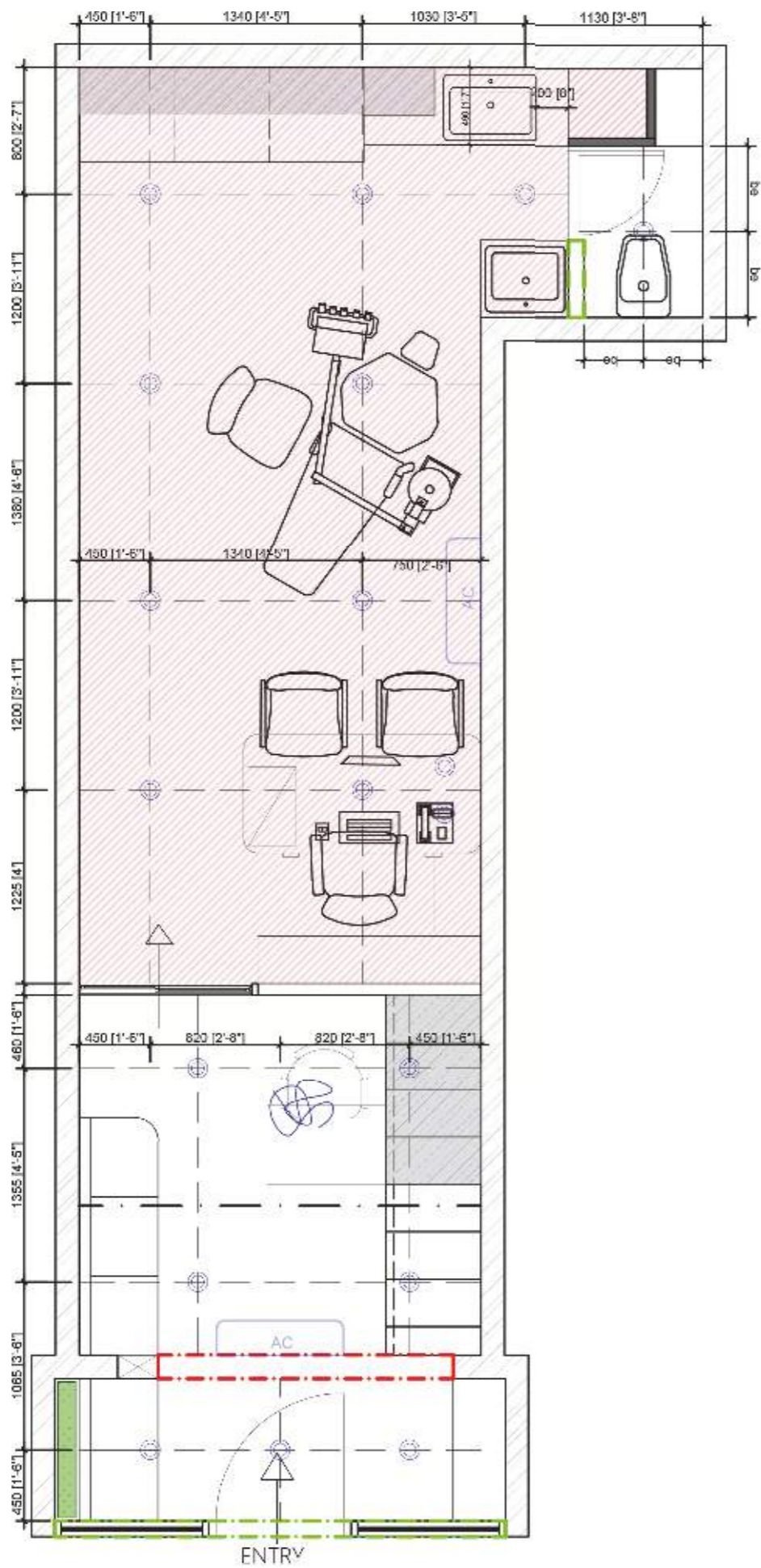

RCP Layout

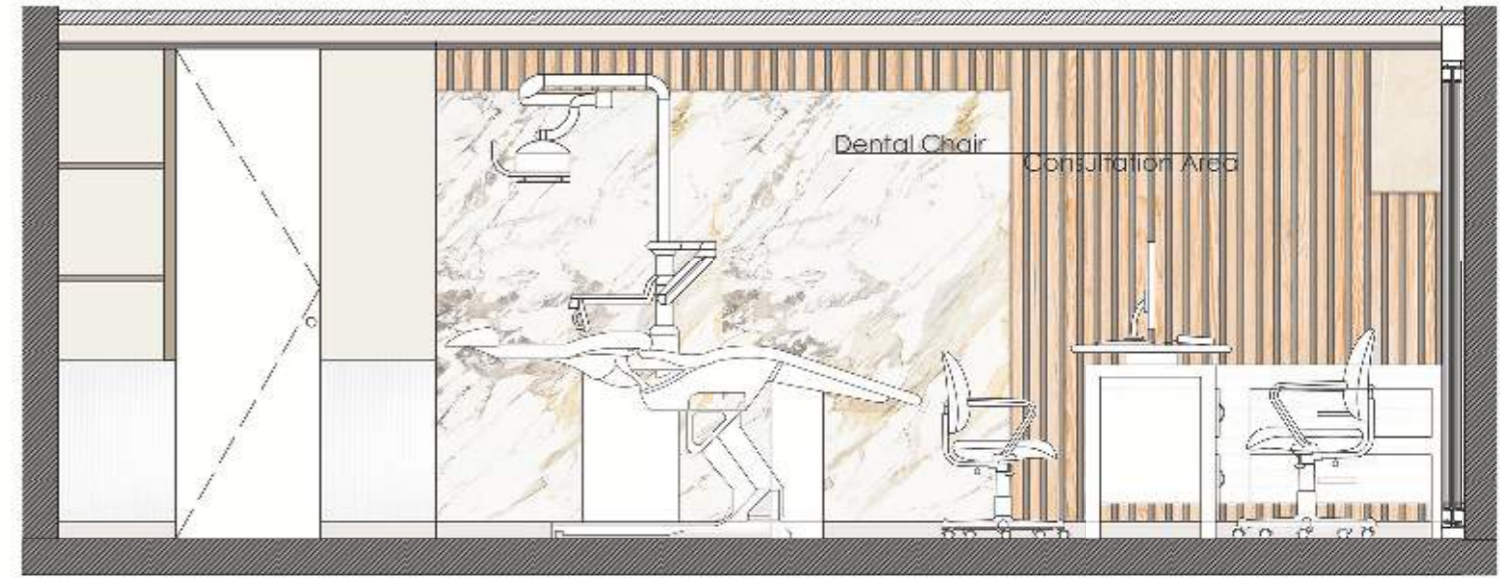

Elevation A

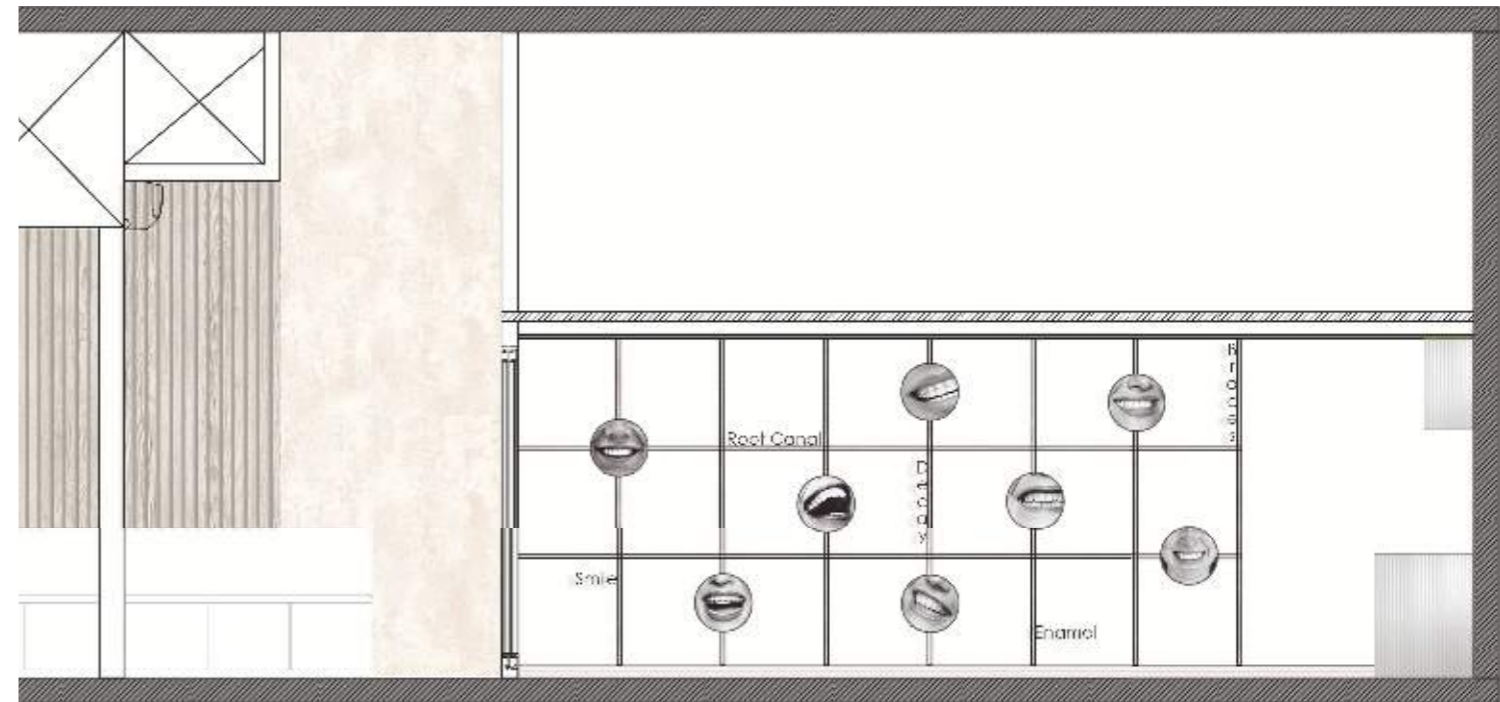

Elevation B



Elevation C

Publications on Urban Design Lab

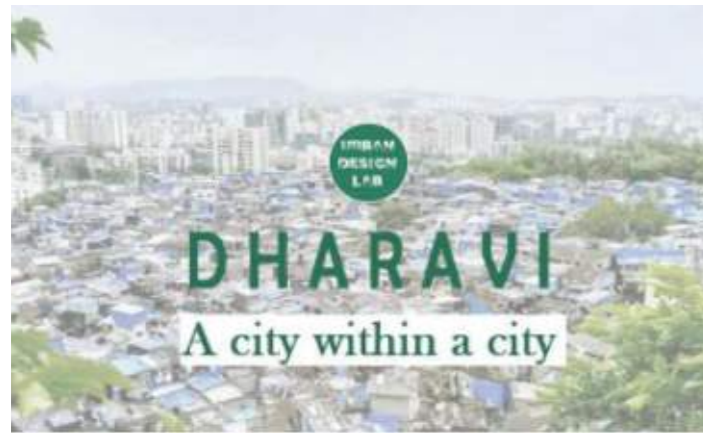

1. Dharavi – A city within a city

Key Topics:
Housing and Infrastructure, Urban Economy, Urban Sociology

Date Published:
April 13, 2022



2. Makeshift Urbanism: Rekindling the underutilized spaces of Mumbai

Key Topics:
New Urbanism, Urban Planning, Urban Sprawl

Date Published:
February 27, 2022



3. Recalibrating Living Dimensions of Heritage Sites

Key Topics:
Culture, heritage, urban conservation, Urbanism

Date Published:
March 14, 2022



4. The New Urbanism: Successes and failures

Key Topics:
Contemporary Urbanism

Date Published:
March 8, 2022

Renderers & Paintings

I own and operate The Local Palette, a small local business on Instagram specializing in handmade paintings. My creations span a variety of mediums, including acrylics, oils, watercolors, and gouache paints.



Acrylic Painting



Gouache Painting



Living room render



Game Ranch-Restaurant Render for Client

Model Making

Model making has played a vital role in my journey as both a student and a professional architect. It's not just about visual representation; it's a dynamic process that fosters creativity and innovation, particularly during the conceptual stages of a project. By crafting physical models, I can experiment hands-on, refine ideas, and uncover new possibilities. This tactile approach helps me understand scale, proportion, and materiality better, leading to more thoughtful designs. Overall, model making is an integral part of my design process, enhancing both the quality and depth of my work.



Watching Tower

Pavilion



30 Models made to Illustrate Design Polarities for Architecture Design Course, Second Semester at NJIT, 2024.

You may connect with me through the following platforms:

Linked In:

<https://www.linkedin.com/in/urvi-b-b7b5329b/>

Instagram for The Local Palette Account:



@THELOCALPALETTE

Phone No. : 5513392926

Email Id: urvibasu1@gmail.com
ub42@njit.edu

